



MASTER CATALOG 2018

VOLUME TWO | **ROTATING TOOLS**



HOLEMAKING | TAPPING | SOLID END MILLING | INDEXABLE MILLING

➤ HTS Series Indexable Deep-Hole Drilling System

Primary Application

HTS series indexable drills are designed for deep-hole drilling up to 10 x D in steel, stainless steel, ductile iron, cast iron, and non-ferrous materials. The two HTS systems — HTS and HTS-R — cover a diameter range of 40–270mm (1.575–10.629").



Features and Benefits

HTS Indexable Drill System

- Large diameter range from 45–270mm (1.750–10.629") with standard drill heads.
- Drill Fix™ DFT™ trigon inserts as outboard and inboard insert offer the best centering capabilities; square-outboard insert cartridges offer increased surface and hole quality.
- Various insert geometries and grades available as standard.
- Adjust drilling depth and diameter range with suitable extensions and reducers.
- Diameter adjustment by shortening outer cartridge.
- Customized drilling heads up to 540mm (21.259").



HTS-R Indexable Drill System

- Modular system uses drill heads equipped with DFR™ insert cartridges.
- Five drill heads cover the diameter range 40–55mm (1.575–2.165").
- Drill Fix™ DFR rectangular inboard and outboard inserts offer the highest feed rates at small diameters.
- Various insert geometries and grades available as standard.
- Adjust drilling depth and diameters by using extensions and reducers.
- Diameter adjustment by shortening outer cartridge.

➤ HTS Indexable Drill System

The HTS indexable drill system is one of the most reliable deep-hole drilling systems available. Drilling up to 10 x D can be easily achieved in materials like steel, stainless steel, ductile iron, cast iron, and non-ferrous materials. Various drilling heads cover the diameter range 45–270mm (1.77–10.63").

HTS drill heads are equipped with pilot drills and cartridges using trigon-shaped Drill Fix™ DFT™ inserts. Use HTS extensions and reducers to achieve various diameters and depths of drilling.

For improved surface qualities and increased reliability, finishing HTS cartridges with a squared-outboard insert are available as standard.

Features and Benefits

Productivity

- Achieve high hole accuracy by using pilot drills and trigon-shaped inserts.
- Benefit from improved surface qualities using finishing cartridges with squared-outboard inserts.
- Adjust outer cartridge to desired cutting diameter, reducing inventory.
- Same insert size is used in each insert cartridge, reducing inventory costs.

Versatility

- Diameter range covering 45–270mm (1.77–10.63").
- L/D ratio up to 10 x D as standard.
- Inserts and pilot drills can be used with various heads and cartridges, covering various diameters.
- Large variety of DFT insert grades and geometries available.
- Finishing cartridge with squared-outboard insert offering four cutting edges for high process stability.
- Carbide pilot drills are available upon request.

Use HTS extensions and reducers to achieve various diameters and depths of drilling.

Customization

- Wear pads can be added for increased stability.
- Fully engineered solutions available.
- Custom solutions covering diameter range up to 540mm (21.259") are possible.



➤ HTS-R Indexable Drill System

HTS-R extends the HTS system by covering diameters between 40–55mm (1.575–2.165").

Up to 30% higher feed rates achievable with rectangular-shaped Drill Fix™ DFR™ inserts with the added benefit of improved chip control.

Features and Benefits

Productivity

- Benefit from better chip control and higher insert stability for longer tool body life.
- Same insert size is used in each insert cartridge.

Versatility

- Diameter range covering 40–55mm (1.575–2.165") with five drilling heads.
- Large variety of DFR insert grades and geometries available.
- Outer cartridges can be adjusted to the desired cutting diameter.
- Extensions and reducers are available as standard.
- Solid carbide and HSS pilot drills are available to match the cutting conditions of specific applications.

Benefit from better chip control and higher insert stability for longer tool body life.



Pilot drill should be installed and set to the proper length before installing the inner cartridge.



Install inner cartridge, then the outer insert.



Install inner insert into cartridge.

Customization

- Wear pads can be added for increased stability.
- Fully engineered solutions available.



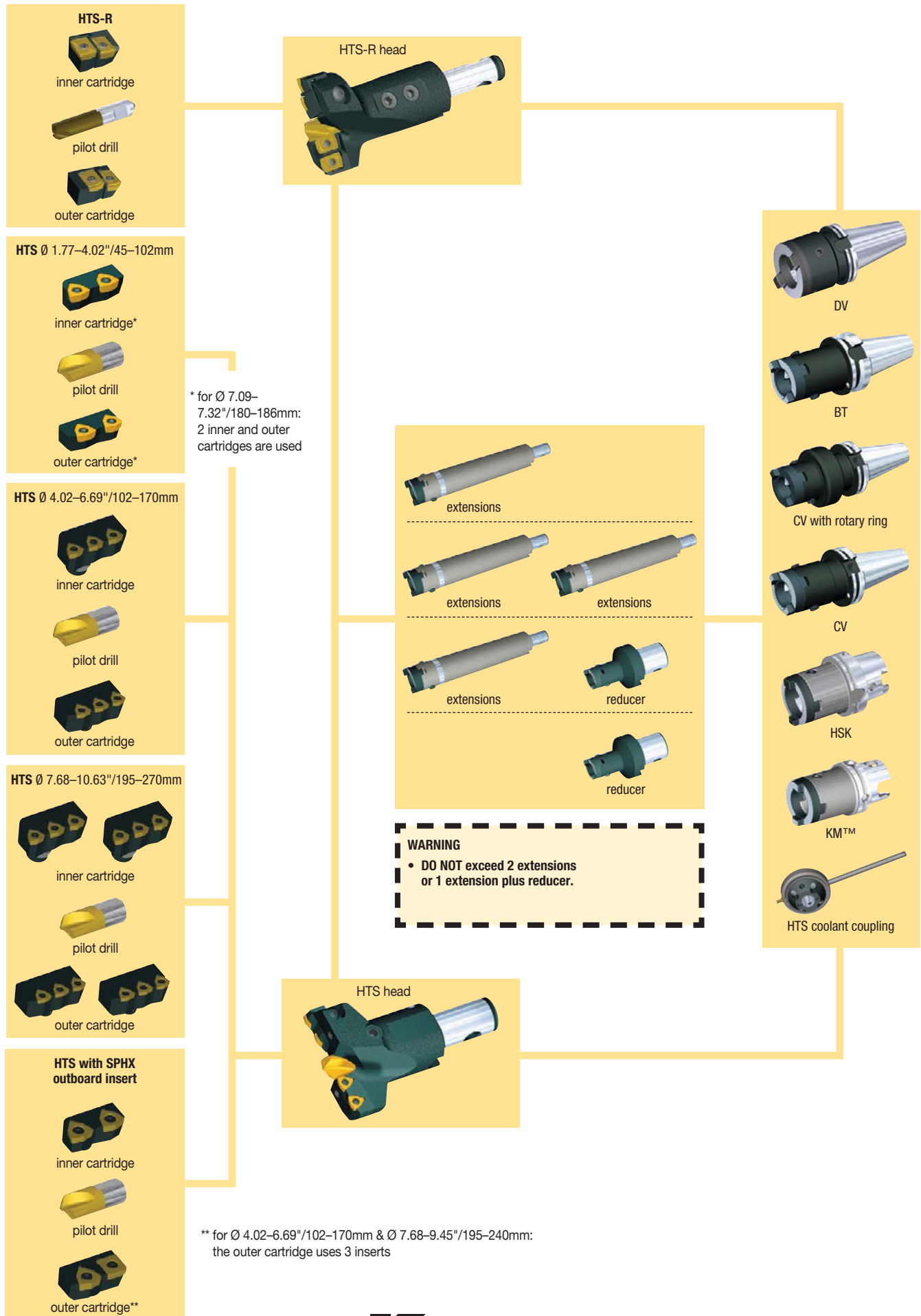

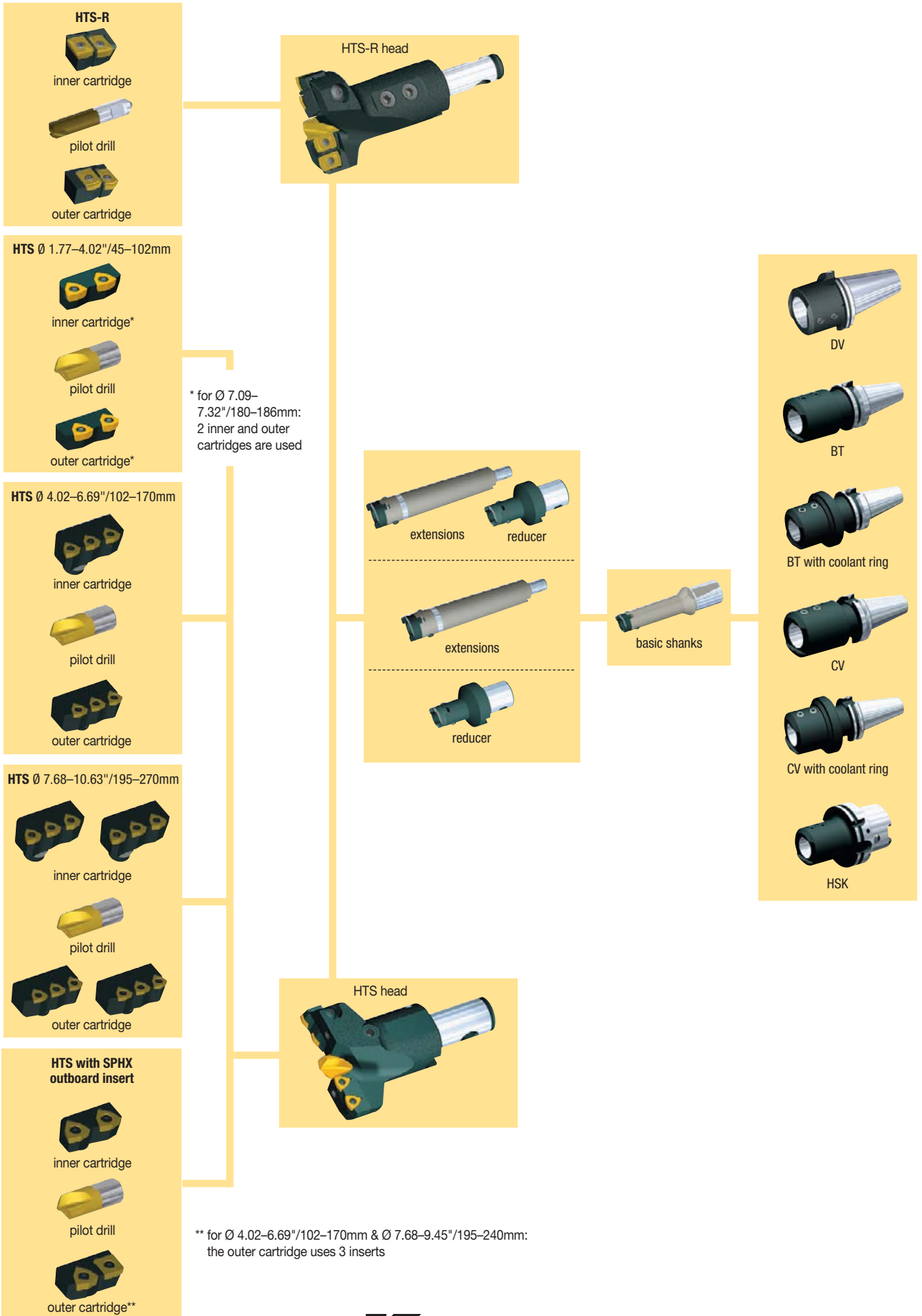







To assemble your HTS(-R) head, choose the desired drill diameter range from the left-hand column.

Next, follow the columns to the right, and select the appropriate component from each column to complete your HTS(-R) head.







drilling range			HTS(-R) head with DFR™/DFT™ inserts										
			L1				inner cartridge			outer cartridge			pilot drill
mm	in	HTS head	mm	in	cartridge	n	insert	n	cartridge	n	insert	n	
40–43	1.57–1.69	HTSR040R025M	60	2.36		1		2		1		2	
43–46	1.69–1.81	HTSR043R025M	70	2.76	HTSR11CI	1	DFR0302	2	HTSR11CE	1	DFR0302	2	B513S10
46–49	1.81–1.93	HTSR046R028M			HTSR12CI	1	DFR0403	2	HTSR12CE	1	DFR0403	2	B513S10
49–52	1.93–2.05	HTSR049R028M			HTSR13CI	1	DFR0403	2	HTSR13CE	1	DFR0403..	2	B513S10
52–55	2.05–2.17	HTSR052R028M			HTSR14CI	1	DFR0403	2	HTSR14CE	1	DFR0403..	2	B513S10

drilling range	mm	in	HTS head	HTS(-R) head with DFR™/DFT™ inserts										
				mm	in	cartridge	n	insert	n	cartridge	n	insert	n	pilot drill
HTS heads with DFT/SPHX inserts	45–50	1.77–1.97	3.76045R028V	50	1.97	3.77000R050V	1	DFT0303	2	3.77000R051V	1	DFT0303	2	B510S08
	50–55	1.97–2.17	3.76050R028V			3.77000R052V	1	DFT0303	2	3.77000R053V	1	DFT0303	2	B510S08
	55–58	2.17–2.28	3.76055R032V	60	2.36	3.77000R038V	1	DFT05T3	2	3.77000R039V	1	DFT05T3	2	B510S08
	58–63	2.28–2.48	3.76058R032V			3.77000R023V	1	DFT05T3	2	3.77000R024V	1	DFT05T3	2	B510S10
	63–68	2.48–2.68	3.76063R032V			3.77000R025V	1	DFT05T3	2	3.77000R024V	1	DFT05T3	2	B510S10
	63–68	2.48–2.68	3.76063R040V*			70	2.76	3.77000R025V	1	DFT05T3	2	3.77000R024V	1	DFT05T3
	68–73	2.68–2.87	3.76068R040V	3.77000R026V	1			DFT05T3	2	3.77000R027V	1	DFT05T3	2	B510S10
	73–78	2.87–3.07	3.76073R040V	3.77000R026V	1			DFT05T3	2	3.77000R027V	1	DFT05T3	2	B510S15
	78–84	3.07–3.31	3.76078R040V	3.77000R028V	1			DFT06T3	2	3.77000R029V	1	DFT06T3	2	B510S15
	78–84	3.07–3.31	3.76078R048V*	70	2.76	3.77000R028V	1	DFT06T3	2	3.77000R029V	1	DFT06T3	2	B510S15
	84–90	3.31–3.54	3.76084R048V			3.77000R028V	1	DFT06T3	2	3.77000R029V	1	DFT06T3	2	B510S15
	90–94°	3.54–3.70	3.76090R048V			–	–	–	–	–	–	–	–	–
	90–96	3.54–3.78	3.76090R048V			3.77000R030V	1	DFT06T3	2	3.77000R031V	1	DFT06T3	2	B510S15
	96–100°	3.78–3.93	3.76096R048V	–	–	–	–	–	–	–	–	–		
	96–102	3.78–4.02	3.76096R048V	3.77000R030V	1	DFT06T3	2	3.77000R031V	1	DFT06T3	2	B510S20		
	96–100°	3.78–3.93	3.76096R058V*	80	3.15	–	–	–	–	–	–	–	–	
	96–102	3.78–4.02	3.76096R058V*			3.77000R030V	1	DFT06T3	2	3.77000R031V	1	DFT06T3	2	B510S20
	102–108	4.02–4.25	3.76102R058V			3.77000R081V	1	DFT05T3	3	3.77000R082V	1	DFT05T3	3	B510S20
	108–115	4.25–4.53	3.76108R058V			3.77000R083V	1	DFT06T3	3	3.77000R084V	1	DFT06T3	3	B510S20
	115–122	4.53–4.80	3.76115R070V	90	3.54	3.77000R085V	1	DFT06T3	3	3.77000R086V	1	DFT06T3	3	B510S25
	122–130	4.80–5.12	3.76122R070V			3.77000R079V	1	DFT06T3	3	3.77000R080V	1	DFT06T3	3	B510S25
	130–140	5.12–5.51	3.76130R070V			3.77000R087V	1	DFT06T3	3	3.77000R088V	1	DFT06T3	3	B510S25
	140–150	5.51–5.91	3.76140R080V			3.77000R077V	1	DFT0704	3	3.77000R078V	1	DFT0704	3	B510S25
	150–158	5.91–6.22	3.76150R080V	100	3.94	3.77000R075V	1	DFT0704	3	3.77000R076V	1	DFT0704	3	B510S25
	158–162	6.22–6.38	3.76158R080V			3.77000R073V	1	DFT0704	3	3.77000R074V	1	DFT0704	3	B510S25
	162–170	6.38–6.70	3.76162R080V			3.77000R048V	1	DFT0704	3	3.77000R049V	1	DFT0704	3	B510S30
	180–184°	7.08–7.24	3.76180R110			–	–	–	–	–	–	–	–	–
	180–186	7.08–7.32	3.76180R110	125	4.92	3.77000R030V	3	DFT06T3	4	3.77000R031V	1	DFT06T3	4	B510S30
195–201	7.68–7.91	3.76195R110	3.77000R081V			3	DFT05T3	6	3.77000R082V	1	DFT05T3	6	B510S30	
213–220	8.39–8.66	3.76213R125	3.77000R083V			3	DFT06T3	6	3.77000R084V	1	DFT06T3	6	B510S30	
230–240	9.06–9.45	3.76230R160	150	5.91	3.77000R079V	2	DFT06T3	6	3.77000R080V	2	DFT06T3	6	B510S30	
260–270	10.24–10.63	3.76260R160			3.77000R077V	2	DFT06T3	6	3.77000R078V	2	DFT06T3	6	B510S30	

° Decreased diameter range by using SPHX insert in exterior cartridge.

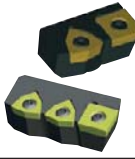
* Drill heads with reinforced body for short-chipping materials.

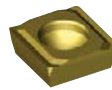
n = Required quantity.

HTS head with DFT™ inserts and SPHX outboard insert													
inner cartridge							outer cartridge						pilot drill
													
cartridge	n	cartridge	n	insert	n	cartridge	n	insert	n	insert	n	pilot drill	
-	-	-	-	-	-	-	-	-	-	-	-	-	-
-	-	-	-	-	-	-	-	-	-	-	-	-	-
-	-	-	-	-	-	-	-	-	-	-	-	-	-
-	-	-	-	-	-	-	-	-	-	-	-	-	-
-	-	-	-	-	-	-	-	-	-	-	-	-	-

3.77000R250V	1	-	-	DFT0303.	2	3.77000R251V	1	DFT0303.	1	SPHX0703.	1	B510S08.
3.77000R252V	1	-	-	DFT0303.	2	3.77000R253V	1	DFT0303.	1	SPHX0703.	1	B510S08.
3.77000R038V	1	-	-	DFT05T3.	2	3.77000R239V	1	DFT05T3.	1	SPHX0903.	1	B510S08.
3.77000R023V	1	-	-	DFT05T3.	2	3.77000R224V	1	DFT05T3.	1	SPHX0903.	1	B510S10.
3.77000R025V	1	-	-	DFT05T3.	2	3.77000R224V	1	DFT05T3.	1	SPHX0903.	1	B510S10.
3.77000R025V	1	-	-	DFT05T3.	2	3.77000R224V	1	DFT05T3.	1	SPHX0903.	1	B510S10.
3.77000R026V	1	-	-	DFT05T3.	2	3.77000R227V	1	DFT05T3.	1	SPHX0903.	1	B510S10.
3.77000R026V	1	-	-	DFT05T3.	2	3.77000R227V	1	DFT05T3.	1	SPHX0903.	1	B510S15.
3.77000R028V	1	-	-	DFT06T3.	2	3.77000R229V	1	DFT06T3.	1	SPHX0903.	1	B510S15.
3.77000R028V	1	-	-	DFT06T3.	2	3.77000R229V	1	DFT06T3.	1	SPHX0903.	1	B510S15.
3.77000R228V	1	-	-	DFT06T3.	2	3.77000R229V	1	DFT06T3.	1	SPHX0903.	1	B510S15.
3.77000R230V	1	-	-	DFT06T3.	2	3.77000R231V	1	DFT06T3.	1	SPHX0903.	1	B510S15.
-	-	-	-	-	-	-	-	-	-	-	-	-
3.77000R230V	1	-	-	DFT06T3.	2	3.77000R231V	1	DFT06T3.	1	SPHX0903.	1	B510S20.
-	-	-	-	-	-	-	-	-	-	-	-	-
3.77000R230V	1	-	-	DFT06T3.	2	3.77000R231V	1	DFT06T3.	1	SPHX0903.	1	B510S20.
-	-	-	-	-	-	-	-	-	-	-	-	-
3.77000R081V	1	-	-	DFT05T3.	3	3.77000R282V	1	DFT05T3.	2	SPHX0903.	1	B510S20.
3.77000R083V	1	-	-	DFT06T3.	3	3.77000R284V	1	DFT06T3.	2	SPHX1204.	1	B510S20.
3.77000R085V	1	-	-	DFT06T3.	3	3.77000R286V	1	DFT06T3.	2	SPHX1204.	1	B510S25.
3.77000R079V	1	-	-	DFT06T3.	3	3.77000R280V	1	DFT06T3.	2	SPHX1204.	1	B510S25.
3.77000R087V	1	-	-	DFT06T3.	3	3.77000R288V	1	DFT06T3.	2	SPHX1204.	1	B510S25.
3.77000R077V	1	-	-	DFT0704.	3	3.77000R278V	1	DFT0704.	2	SPHX1505.	1	B510S25.
3.77000R075V	1	-	-	DFT0704.	3	3.77000R276V	1	DFT0704.	2	SPHX1204.	1	B510S25.
3.77000R073V	1	-	-	DFT0704.	3	3.77000R274V	1	DFT0704.	2	SPHX1204.	1	B510S25.
3.77000R248V	1	-	-	DFT0704.	3	3.77000R249V	1	DFT0704.	2	SPHX1505.	1	B510S30.
3.77000R230V	3	-	-	DFT06T3.	4	3.77000R231V	1	DFT06T3.	3	SPHX0903.	1	B510S30.
-	-	-	-	-	-	-	-	-	-	-	-	-
3.77000R081V	3	-	-	DFT05T3.	9	3.77000R282V	1	DFT05T3.	2	SPHX0903.	1	B510S30.
3.77000R083V	3	-	-	DFT06T3.	9	3.77000R284V	1	DFT06T3.	2	SPHX1204.	1	B510S30.
3.77000R079V	2	3.77000R080V	1	DFT06T3.	9	3.77000R280V	1	DFT06T3.	2	SPHX1204.	1	B510S30.
-	-	-	-	-	-	-	-	-	-	-	-	B510S30

HTS Tool Assembly Combinations

- Select your appropriate drill diameter range.
- Choose the appropriate adapter and shank size.
- Follow the columns to the right, and select the appropriate components from each column to complete your HTS(-R) tool.

drilling range		shank		DV		BT		CV		HSK													
				assembly details		assembly details		assembly details		assembly details													
mm	in		D1	40	50	40	50	40	50	50/63/100													
HTS heads with DFR™ inserts													40-43 43-46	1.57-1.69 1.69-1.81	WD/ WN	32	DV40BWD32075M DV40RMWD32115M**	DV50BWD32060M DV50RMWD32140M**	BT40BWD32070M	BT50BWD32080M	CV40BWD32M343 CV40RMWD32M453**	CV50BWD32M343 CV50RMWD32M453**	HSK50ASWN32110M HSK63ASWN32090M HSK100ASWN32100M
																50	-	DV50BWD50075M DV50RMWD50144M**	-	BT50BWD50085M BT50RMWD50162M**	-	CV50BWD50M343 CV50RMWD50M472**	-
													46-49 49-52 52-55	1.81-1.93 1.93-2.05 2.05-2.17	SS(F)	1.50	-	-	-	-	CV40BSSF150575	CV50SS150400 (AD) CV50SS150600 (AD) CV50SS150800 (AD) CV50BSSF150450	-
																HTS	50	-	5.36050-154050	-	BT50BHTS50080M	-	CV50BHTS50M314 CV50RMHTS50M413**
													55-58 58-63 63-68	2.17-2.28 2.28-2.48 2.48-2.68	WD/ WN		32	DV40BWD32075M DV40RMWD32115M**	DV50BWD32060M DV50RMWD32140M**	BT40BWD32070M	BT50BWD32080M	CV40BWD32M343 CV40RMWD32M453**	CV50BWD32M343 CV50RMWD32M453**
																50	-	DV50BWD50075M DV50RMWD50144M**	-	BT50BWD50085M BT50RMWD50162M**	-	CV50BWD50M343 CV50RMWD50M472**	HSK100ASWN50110M
															SS(F)	2.00	-	-	-	-	-	CV50SS200562 (AD) CV50SS200762 (AD) CV50BSSF200550	-
																HTS	50	-	5.36050-154050	-	BT50BHTS50080M	-	CV50BHTS50M314 CV50RMHTS50M413**
63-68* 68-73 73-78 78-84	2.48-2.68 2.68-2.87 2.87-3.07 3.07-3.31	WD/ WN	50	-	DV50BWD50075M DV50RMWD50144M**	-	BT50BWD50085M BT50RMWD50162M**	-	CV50BWD50M343 CV50RMWD50M472**	HSK100ASWN50110M													
			SS(F)	2.00	-	-	-	-	CV50SS200562 (AD) CV50SS200762 (AD) CV50BSSF200550	-													
		HTS		50	-	5.36050-154050	-	BT50BHTS50080M	-	CV50BHTS50M314 CV50RMHTS50M413**	-												
			50	-	5.36050-154050	-	BT50BHTS50080M	-	CV50BHTS50M314 CV50RMHTS50M413**	-													

* HTS drilling head with reinforced body for short-chipping materials.

** Adapter with coolant ring.

The shown combinations are not complete. Ask your Kennametal representative to get the most reasonable solution for your application. Please note that the assembled total length of the drilling tool is not necessarily the total achievable drilling depth.

KM	basic shank					reducer			for use with coolant adapter		extension			HTS head
	assembly details	L4	L4	L4	L4	L1					L1			
80	metric	mm	inch	in		mm	in	coolant adapter	shell mill DV/BT		mm	in		
-	5.34032-025115 5.34032-025200	110 195	-	-	-	-	-	-	-	-	-	-	-	
-	5.34050-025300 5.34050-025450	270 420	-	-	-	-	-	-	-	-	5.34125R025150	160	6.30	HTSR040R025M HTSR043R025M
-	-	-	SSF150HTS130239 SSF150HTS130664 SSF150HTS131114 SSF150HTS131764	.39 4.65 9.14 15.64	-	-	-	-	-	-	-	-	-	-
-	5.34032-028115 5.34032-028200	110 195	-	-	-	-	-	-	-	-	-	-	-	
-	5.34050-028300 5.34050-028450	265 415	-	-	-	-	-	-	-	-	-	-	-	
-	-	-	SSF200HTS130239 SSF200HTS130664 SSF200HTS131114 SSF200HTS131764	.39 4.65 9.14 15.64	-	-	-	-	-	-	5.34128R028150	160	6.30	HTSR046R028M HTSR049R028M HTSR052R028M
KM80ATCHTS50085M KM80ATCHTS50100M	-	-	-	-	-	5.34280R028080	90	3.54	5.34350-090100	DV50SM60070M BT50SM60090M	-	-	-	
-	5.34032-025115 5.34032-025200	110 195	-	-	-	-	-	-	-	-	-	-	-	
-	5.34050-028300 5.34050-028450	265 415	-	-	-	-	-	-	-	-	-	-	-	
-	-	-	SSF200HTS130239 SSF200HTS130664 SSF200HTS131114 SSF200HTS131764	.39 4.65 9.14 15.64	-	-	-	-	-	-	5.34128R028150	160	6.30	3.76045R028V 3.76050R028V
KM80ATCHTS50085M KM80ATCHTS50100M	-	-	-	-	-	5.34280R028080	90	3.54	5.34350-090100	DV50SM60070M BT50SM60090M	-	-	-	
-	5.34032-032125	120	-	-	-	-	-	-	-	-	-	-	-	
-	5.34050-032500 5.34050-032350 5.34050-032350	165 315 465	-	-	-	-	-	-	-	-	-	-	-	
-	-	-	SSF200HTS160239 SSF200HTS160714 SSF200HTS161214 SSF200HTS161964	.39 5.14 10.14 17.64	-	-	-	-	-	-	5.34132R032100 5.34132R032200	110 210	4.33 8.27	3.76055R032V 3.76058R032V 3.76063R032V
KM80ATCHTS50085M KM80ATCHTS50100M	-	-	-	-	-	5.34280R032080	90	3.5	5.34350-090100	DV50SM60070M BT50SM60090M	-	-	-	
-	5.34050-040148 5.34050-040300 5.34050-040450 5.34050-040600	140 267 417 567	-	-	-	-	-	-	-	-	-	-	-	
-	-	-	SSF200HTS220297 SSF200HTS220922 SSF200HTS221572 SSF200HTS222572	.47 7.22 13.72 23.72	-	-	-	-	-	-	5.34140R040200	212	8.35	3.76063R040V* 3.76068R040V 3.76073R040V 3.76078R040V
KM80ATCHTS50085M KM80ATCHTS50100M	-	-	-	-	-	5.34280R040080	90	3.62	5.34350-090100	DV50SM60070M BT50SM60090M	-	-	-	

(continued)

(HTS Tool Assembly Combinations — continued)

HTS Tool Assembly Combinations

- Select your appropriate drill diameter range.
- Choose the appropriate adapter and shank size.
- Follow the columns to the right, and select the appropriate components from each column to complete your HTS(-R) tool.

drilling range		shank		DV		BT		CV		HSK
				assembly details		assembly details		assembly details		assembly details
mm	in		D1	40	50	40	50	40	50	50/63/100
78–84* 84–90 90–96 96–102	3.07–3.31 3.31–3.54 3.54–3.70 3.78–4.02	WD/ WN	50	–	DV50BWD50075M DV50RMWD50144M**	–	BT50BWD50085M BT50RMWD50162M**	–	CV50BWD50M343 CV50RMWD50M472**	HSK100ASWN50110M
		SS(F)	2.00	–	–	–	–	–	CV50SS200562 (AD) CV50SS200762 (AD) CV50BSSF200550	–
		HTS	50	–	5.36050–154050	–	BT50BHTS50080M	–	CV50BHTS50M314 CV50RMHTS50M413**	–
96–102* 102–108 108–115	3.78–4.02 4.02–4.25 4.25–4.53	WD/ WN	50	–	DV50BWD50075M DV50RMWD50144M**	–	BT50BWD50085M BT50RMWD50162M**	–	CV50BWD50M343 CV50RMWD50M472**	HSK100ASWN50110M
		SS(F)	2.00	–	–	–	–	–	CV50SS200562 (AD) CV50SS200762 (AD) CV50BSSF200550	–
		HTS	50	–	5.36050–154050	–	BT50BHTS50080M	–	CV50BHTS50M314 CV50RMHTS50M413**	–
115–122 122–130 130–140	4.53–4.80 4.80–5.12 5.12–5.51	SS(F)	40	–	–	–	–	–	CV50SS250800	–
		HTS	40	5.36050154040	–	BT50BHTS40080M	–	CV50BHTS40M314 CV50RMHTS40M412**	–	HSK100AHTS40085M
			50	–	5.36050–154050	–	BT50BHTS50080M	–	CV50BHTS50M314 CV50RMHTS50M413**	HSK100AHTS50090M
140–150 150–158 158–162 162–170	5.51–5.91 5.91–6.22 6.22–6.38 6.38–6.70	HTS	50	–	5.36050–154050	–	BT50BHTS50080M	–	CV50BHTS50M314 CV50RMHTS50M413**	HSK100AHTS50090M
180–186 195–201 213–220	7.08–7.32 7.68–7.91 8.39–8.66	customized solutions available upon request								
230–240 260–270	9.06–9.45 10.24–10.63	customized solutions available upon request								

* HTS drilling head with reinforced body for short-chipping materials.

** Adapter with coolant ring.

The shown combinations are not complete. Ask your Kennametal representative to get the most reasonable solution for your application.

Please note that the assembled total length of the drilling tool is not necessarily the total achievable drilling depth.

KM	basic shank					reducer			for use with coolant adapter		extension			HTS head
	assembly details	L4	L4	L4	L4	L1					L1			
80	metric	mm	inch	in		mm	in	coolant adapter	shell mill DV/BT		mm	in		
-	5.34050-048168 5.34050-048300 5.34050-048450 5.34050-048600	160 267 417 567	-	-	-	-	-	-	-	-	-	-	-	-
-	-	-	SSF200HTS270297 SSF200HTS271122 SSF200HTS271922 SSF200HTS273122	1.47 9.22 17.22 29.22	-	-	-	-	-	-	5.34140R048200	212	8.35	3.76078R048V* 3.76084R048V 3.76090R048V 3.76096R048V
KM80ATCHTS50085M KM80ATCHTS50100M	-	-	-	-	5.34280R048080	92	3.62	5.34350-090100	DV50SM60070M BT50SM60090M	-	-	-	-	-
-	5.34050-058186 5.34050-058300 5.34050-058450 5.34050-058600	180 254 404 554	-	-	-	-	-	-	-	-	-	-	-	-
-	-	-	SSF200HTS160239 SSF200HTS160714 SSF200HTS161214 SSF200HTS161964	.39 5.14 10.14 17.64	-	-	-	-	-	-	5.34158R058300	314	12.36	3.76096R058V* 3.76102R058V 3.76108R058V
KM80ATCHTS50085M KM80ATCHTS50100M	-	-	-	-	5.34280R058080	94	3.70	5.34350-090100	DV50SM60070M BT50SM60090M	-	-	-	-	-
-	-	-	SSF250HTS400355 SSF250HTS401055 SSF250HTS401555 SSF250HTS402555	1.63 8.21 13.21 23.21	-	-	-	-	-	-	-	-	-	-
KM80ATCHTS40085M KM80ATCHTS40100M	-	-	-	-	5.34280R070150	164	6.45	5.34350-090100	DV50SM60070M BT50SM60090M	5.34170R070300 5.34170R070500	314 514	12.36 20.24	3.76115R070V 3.76122R070V 3.76130R070V	
KM80ATCHTS50085M KM80ATCHTS50100M	-	-	-	-	-	-	-	-	-	-	-	-	-	-
KM80ATCHTS50085M KM80ATCHTS50100M	-	-	SSF300HTS500413 SSF300HTS501313 SSF300HTS502113 SSF300HTS503113	1.87 10.55 18.55 28.55	-	-	-	5.34350-090100	DV50SM60070M BT50SM60090M	5.34180R080204 5.34180R080300 5.34180R080500	220 316 516	8.66 12.44 20.32	3.76140R080V 3.76150R080V 3.76158R080V 3.76162R080V	
customized solution available upon request													3.76180R110 3.76195R110 3.76213R125	
customized solution available upon request													3.76230R160 3.76260R160	

Adapter

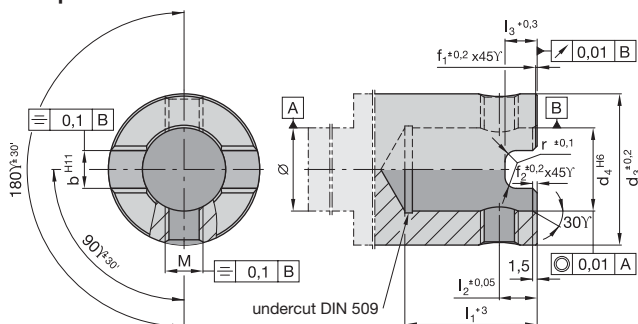

Mounting

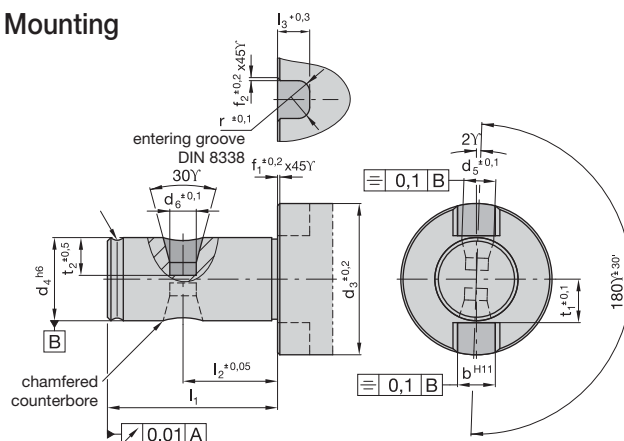

Adapter Dimensions

d3	d4	l1	l2	l3	M	b	r	f1	f2	drive ring	clamping screw	thread	MAN* Nm	sliding block	clamping screw M 12 x 25 for sliding block
25	13	28	12,4	7,0	M8 x 1,0	8,0	3	0,5	0,5	193.371	193.372	M8 x 1,0	10	-	-
28	13	28	12,4	7,0	M8 x 1,0	8,0	3	0,5	0,5	192.419	193.372	M8 x 1,0	10	-	-
32	16	32	14,4	7,5	M8 x 1,0	8,0	3	0,5	0,5	192.420	192.156	M8 x 1,0	10	-	-
40	22	35	13,4	8,5	M10 x 1,0	10,0	3	0,5	0,5	192.421	192.157	M10 x 1,0	16	-	-
48	27	40	15,4	9,0	M12 x 1,0	12,0	3	1,0	1,0	192.422	191.727	M12 x 1,0	16	-	-
58	32	38	15,4	10,0	M12 x 1,0	14,0	3	1,0	1,0	192.423	191.727	M12 x 1,0	20	-	-
70	40	43	16,4	10,0	M16 x 1,5	16,0	3	1,0	1,0	192.424	191.728	M16 x 1,5	34	-	-
80	50	46	20,4	12,5	M16 x 1,5	18,0	4	1,0	1,0	192.425	191.728	M16 x 1,5	34	-	-
90	50	46	20,4	12,5	M16 x 1,5	18,0	4	1,0	1,0	192.426	191.729	M16 x 1,5	34	-	-
110	60	46	20,4	12,5	M16 x 1,5	20,0	4	1,0	1,0	192.427	191.729	M16 x 1,5	34	-	-
125 1)	60	77	40,0	12,5	M24 x 2,0	25,5	4	1,0	1,0	-	193.107	M24 x 2,0	120	191.019	125.225
140 1)	70	82	40,0	12,5	M24 x 2,0	25,5	4	1,0	1,0	-	193.107	M24 x 2,0	120	191.019	125.225
160 1)	80	82	40,0	12,5	M24 x 2,0	25,5	4	1,0	1,0	-	193.107	M24 x 2,0	120	191.019	125.225

* MAN = Clamping torque of clamping screw in Nm.

Mounting Dimensions

d3	d4	d5	d6	l1	l2	l3	t1	t2	b	r	f1	f2
25	13	8,50	6,5	35	22,0	7,00	6,7	6,50	8,0	3	0,5	0,5
28	13	8,50	6,5	35	22,0	7,00	7,0	6,50	8,0	3	0,5	0,5
32	16	8,30	6,5	40	24,0	7,50	8,5	7,50	8,0	3	0,5	0,5
40	22	10,50	7,0	45	25,0	8,50	11,5	10,00	10,0	3	0,5	0,5
48	27	12,75	9,0	50	27,0	9,00	14,0	12,00	12,0	3	1,0	1,0
58	32	11,50	9,0	50	29,0	10,00	16,5	7,25	14,0	3	1,0	1,0
70	40	15,25	12,2	55	30,0	10,50	20,5	10,00	16,0	3	1,0	1,0
80	50	15,25	12,2	60	36,0	12,50	25,5	12,50	18,0	4	1,0	1,0
90	50	16,50	12,2	60	36,0	12,50	25,5	12,50	18,0	4	1,0	1,0
110	60	14,50	12,2	60	36,0	13,65	30,5	10,00	20,0	4	1,0	1,0
125 1)	60	25,00	18,0	75	39,5	17,00	35,0	20,25	25,5	6	1,0	1,0
140 1)	70	25,00	18,0	80	39,5	17,00	42,0	20,25	25,5	6	1,0	1,0
160 1)	80	25,00	18,0	80	39,5	17,00	42,0	20,25	25,5	6	1,0	1,0

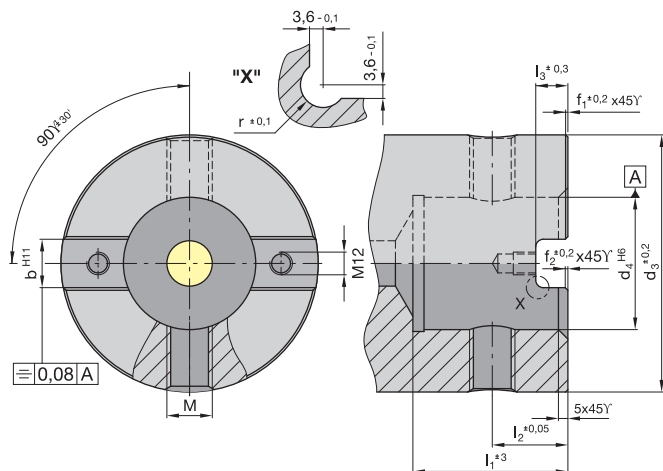

1) Adapter for d3 = 125, 140, and 160

- Head shipped with clamping and adjusting screws.
- Order pilot drill and cartridges separately; see page J76 for pilot drill.

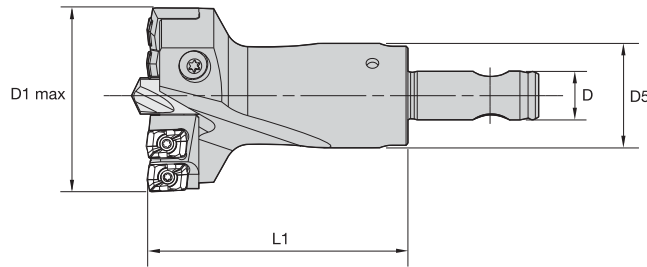

HTS Adjustable Heads with DFR™ Inserts

catalog number	D1		D1 max		D5		L1										
	mm	in	mm	in	mm	in	D	mm	in	pilot drill HSS	pilot drill carbide	interior	n	exterior	n	gauge insert	ni
HTSR040R025M	40	1.57	43	1.69	25	0.98	13A	60	2	B513S08..	B514S08..	HTSR10CI	1	HTSR10CE	1	DFR0302..	4
HTSR043R025M	43	1.69	46	1.81	25	0.98	13A	70	3	B513S10..	B514S10..	HTSR11CI	1	HTSR11CE	1	DFR0302..	4
HTSR046R028M	46	1.81	49	1.93	28	1.10	13B	70	3	B513S10..	B514S10..	HTSR12CI	1	HTSR12CE	1	DFR0403..	4
HTSR049R028M	49	1.93	52	2.05	28	1.10	13B	70	3	B513S10..	B514S10..	HTSR13CI	1	HTSR13CE	1	DFR0403..	4
HTSR052R028M	52	2.05	55	2.17	28	1.10	13B	70	3	B513S10..	B514S10..	HTSR14CI	1	HTSR14CE	1	DFR0403..	4

NOTE: n: number of cartridges required by head.
ni: number of inserts required by head.

D1 diameter			
mm	in	clamping screw	adjusting screw
40-42	1.57-1.68	190.116	128.610
43-52	1.69 - 2.05	193.397	190.458



HTS DFR Cartridges

catalog number	gage insert	Nm	ft. lbs.		insert screw		cartridge screw		washer
HTSR10CE	DFR0302..	5,0	3.69	192.416	192.416	192.592	192.592	192.902	192.902
HTSR10CI	DFR0302..	5,0	3.69	192.416	192.416	192.592	192.592	192.902	192.902
HTSR11CE	DFR0302..	5,0	3.69	192.416	192.416	192.592	192.592	192.902	192.902
HTSR11CI	DFR0302..	5,0	3.69	192.416	192.416	192.592	192.592	192.902	192.902
HTSR12CE	DFR0403..	5,0	3.69	192.432	192.432	192.592	192.592	192.902	192.902
HTSR12CI	DFR0403..	5,0	3.69	192.432	192.432	192.592	192.592	192.902	192.902
HTSR13CE	DFR0403..	5,0	3.69	192.432	192.432	192.592	192.592	192.902	192.902
HTSR13CI	DFR0403..	5,0	3.69	192.432	192.432	192.592	192.592	192.902	192.902
HTSR14CE	DFR0403..	5,0	3.69	192.432	192.432	192.592	192.592	192.902	192.902
HTSR14CI	DFR0403..	5,0	3.69	192.432	192.432	192.592	192.592	192.902	192.902

- Change drill diameter by shortening the outer cartridge.
- Shorten at 90° to the contact face A and the support face B.
- Shortening reduces the effective drill diameter by 2x the amount removed.

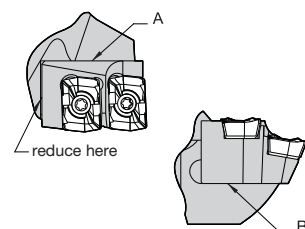

- Choose between HSS and solid carbide.

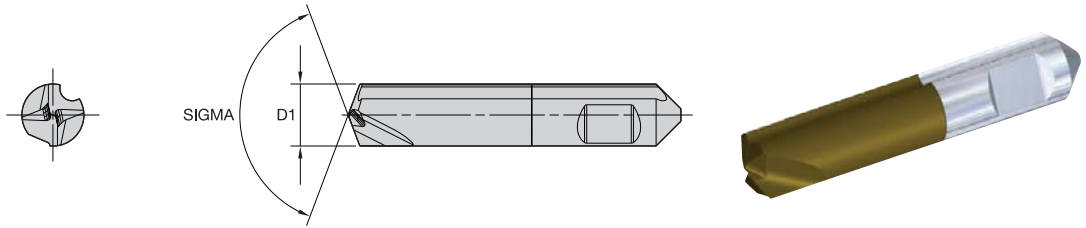

HTS DFR™ • Pilot Drills

Indexable Drills

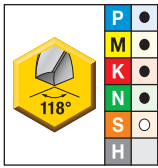

high-speed steel uncoated
A30

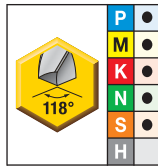

high-speed steel coated
AS3

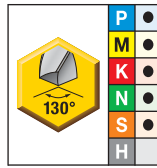

solid carbide coated
KC7030

- first choice
- alternate choice

			D1	
			mm	in
B513S08000 A30	B513S08000 AS3	B514S08000 KC7030	8	.32
B513S10000 A30	B513S10000 AS3	B514S10000 KC7030	10	.39

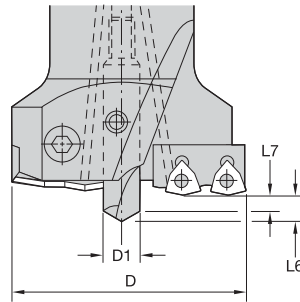

HTS DFR • Pilot Drills

D1		high-speed steel				solid carbide			
mm	in	L6		L7		L6		L7	
mm	in	mm	in	mm	in	mm	in	mm	in
8,00	.315	4,14	.163	1,73	.068	3,61	.142	1,73	.068
10,00	.394	4,88	.192	1,88	.074	4,19	.165	1,88	.074

HTS DFR™ • Metric

Material Group	Condition	Pocket Seat	Geometry	Grade	Metric						
					Cutting Speed – vc			Recommended Feed Rate (f) by Diameter			
					Range – m/min			Ø	DFR03... 40,00–46,00mm	DFR04 46,00–55,00mm	
min	Starting Value	max									
P	1	S	O	MD	KCU25	79	190	229	mm/r	0,10–0,14	0,12–0,18
			I	MD	KCU25						
		U	O	MD	KCU40	71	130	171	mm/r	0,10–0,14	0,12–0,18
			I	MD	KCU40						
	2	S	O	GD	KCU25	75	180	217	mm/r	0,10–0,14	0,12–0,18
			I	GD	KCU25						
		U	O	GD	KCU40	71	120	271	mm/r	0,10–0,14	0,12–0,18
			I	GD	KCU40						
	3	S	O	GD	KCU25	60	140	169	mm/r	0,10–0,14	0,12–0,18
			I	GD	KCU25						
		U	O	GD	KCU40	50	100	121	mm/r	0,10–0,14	0,12–0,18
			I	GD	KCU40						
	4	S	O	GD	KCU25	79	120	229	mm/r	0,10–0,14	0,12–0,18
			I	GD	KCU25						
		U	O	GD	KCU40	71	100	171	mm/r	0,10–0,14	0,12–0,18
			I	GD	KCU40						
	5	S	O	GD	KCU40	62	100	190	mm/r	0,06–0,11	0,07–0,14
			I	GD	KCU40						
		U	O	GD	KCU40	47	60	114	mm/r	0,06–0,11	0,07–0,14
			I	GD	KCU40						
	6	S	O	GD	KCU40	59	95	180	mm/r	0,07–0,11	0,08–0,13
			I	GD	KCU40						
		U	O	GD	KCU40	45	57	108	mm/r	0,07–0,11	0,08–0,13
			I	GD	KCU40						
M	1	S	O	MD	KCU40	40	110	134	mm/r	0,07–0,11	0,12–0,18
			I	MD	KCU40						
		U	O	MD	KCU40	31	70	86	mm/r	0,07–0,11	0,12–0,18
			I	MD	KCU40						
	2	S	O	MD	KCU40	38	99	127	mm/r	0,07–0,11	0,12–0,18
			I	MD	KCU40						
		U	O	MD	KCU40	31	63	86	mm/r	0,07–0,11	0,12–0,18
			I	MD	KCU40						
	3	S	O	MD	KCU40	32	88	107	mm/r	0,07–0,11	0,12–0,18
			I	MD	KCU40						
		U	O	MD	KCU40	31	56	86	mm/r	0,07–0,11	0,12–0,18
			I	MD	KCU40						

Condition: S = Stable cutting conditions;
 U = Unstable cutting conditions;
 I = Interrupted cutting conditions

Pocket seat: I = Inboard insert;
 O = Outboard insert

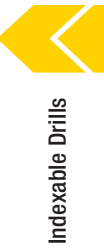

■ HTS DFR™ • Metric

Material Group	Condition	Pocket Seat	Geometry	Grade	Metric					
					Cutting Speed – vc			Recommended Feed Rate (f) by Diameter		
					Range – m/min			Ø	DFR03... 40,00–46,00mm	DFR04... 46,00–55,00mm
min	Starting Value	max								
K	1	O	GD	KCPK10	79	171	229	mm/r	0,11–0,20	0,13–0,27
			GD	KCPK10						
		I	LD	KCU25	64	117	156			
			LD	KCU25						
	2	O	LD	KCU40	40	72	96	mm/r	0,11–0,20	0,13–0,27
			LD	KCU40						
		I	GD	KCPK10	75	162	217			
			GD	KCPK10						
	3	O	GD	KCU25	64	111	156	mm/r	0,11–0,20	0,13–0,27
			GD	KCU25						
		I	LD	KCU40	40	68	96			
			LD	KCU40						
N	1	O	GD	KCPK10	68	146	195	mm/r	0,11–0,20	0,13–0,27
			GD	KCPK10						
		I	GD	KCU25	59	100	144			
			GD	KCU25						
	2	O	GD	KCU40	35	62	84	mm/r	0,11–0,20	0,13–0,27
			GD	KCU40						
I		ST	KD1425	128	240	358				
		ST	KD1425							
3	1	O	LD	KCU40	102	160	239	mm/r	0,06–0,09	0,11–0,19
			LD	KCU40						
		I	LD	KCU40	67	104	155			
			LD	KCU40						
	2	O	ST	KD1425	119	223	333	mm/r	0,06–0,09	0,11–0,19
			ST	KD1425						
I		LD	KCU40	102	149	239				
		LD	KCU40							
4	1	O	LD	KCU40	67	97	155	mm/r	0,06–0,09	0,11–0,19
			LD	KCU40						
		I	ST	KD1425	110	206	308			
			ST	KD1425						
	2	O	LD	KCU40	102	138	239	mm/r	0,06–0,09	0,11–0,19
			LD	KCU40						
I		LD	KCU40	67	89	155				
		LD	KCU40							
5	1	O	ST	KD1425	119	223	333	mm/r	0,06–0,09	0,11–0,19
			ST	KD1425						
		I	LD	KCU40	102	149	239			
			LD	KCU40						
	2	O	LD	KCU40	67	97	155	mm/r	0,06–0,09	0,11–0,19
			LD	KCU40						
I		ST	KD1425	92	220	262				
		ST	KD1425							
3	O	LD	KCU40	72	140	167	mm/r	0,06–0,09	0,11–0,19	
		LD	KCU40							
	I	LD	KCU40	46	90	107				
		LD	KCU40							

Condition: S = Stable cutting conditions;
 U = Unstable cutting conditions;
 I = Interrupted cutting conditions

Pocket seat: I = Inboard insert;
 O = Outboard insert



■ HTS DFR™ • Inch

		Inch									
Material Group	Condition	Pocket Seat	Geometry	Grade	Cutting Speed – vc			Recommended Feed Rate (fz) by Diameter			
					Range – SFM			Ø	DFR03... .688–.750"	DFR04... .813–1.00"	
					min	Starting Value	max				
P	1	S	O	MD	KCU25	260	623	750	IPR	.004–.006	.005–.007
			I	MD	KCU25						
		U	O	MD	KCU40	231	427	561	IPR	.004–.006	.005–.007
			I	MD	KCU40						
		I	O	MD	KC7140	143	262	348	IPR	.003–.006	.004–.008
			I	MD	KC7140						
	2	S	O	GD	KCU25	247	591	712	IPR	.004–.006	.005–.007
			I	GD	KCU25						
		U	O	GD	KCU40	231	394	561	IPR	.004–.006	.005–.007
			I	GD	KCU40						
		I	O	GD	KC7140	143	230	348	IPR	.004–.006	.005–.007
			I	GD	KC7140						
	3	S	O	GD	KCU25	197	459	555	IPR	.004–.006	.005–.007
			I	GD	KCU25						
		U	O	GD	KCU40	163	328	396	IPR	.004–.006	.005–.007
			I	GD	KCU40						
		I	O	GD	KC7140	98	197	238	IPR	.004–.006	.005–.007
			I	GD	KC7140						
	4	S	O	GD	KCU25	260	394	750	IPR	.004–.006	.005–.007
			I	GD	KCU25						
		U	O	GD	KCU40	231	328	561	IPR	.004–.006	.005–.007
			I	GD	KCU40						
		I	O	GD	KC7140	143	262	348	IPR	.004–.006	.005–.007
			I	GD	KC7140						
5	S	O	GD	KCU40	205	328	622	IPR	.002–.004	.003–.006	
		I	GD	KCU40							
	U	O	GD	KC7140	154	197	373	IPR	.002–.004	.003–.006	
		I	GD	KC7140							
	I	O	GD	KC7140	103	131	250	IPR	.002–.004	.003–.006	
		I	GD	KC7140							
6	S	O	GD	KCU40	195	312	591	IPR	.003–.004	.003–.005	
		I	GD	KCU40							
	U	O	GD	KC7140	146	187	355	IPR	.003–.004	.003–.005	
		I	GD	KC7140							
	I	O	GD	KC7140	98	125	238	IPR	.003–.004	.003–.005	
		I	GD	KC7140							
M	1	S	O	MD	KCU40	130	361	439	IPR	.003–.004	.005–.007
			I	MD	KC7140						
		U	O	MD	KC7140	101	230	281	IPR	.003–.004	.005–.007
			I	MD	KC7140						
		I	O	MD	KC7140	72	164	199	IPR	.003–.004	.005–.007
			I	MD	KC7140						
	2	S	O	MD	KCU40	124	325	417	IPR	.003–.004	.005–.007
			I	MD	KC7140						
		U	O	MD	KC7140	101	207	281	IPR	.003–.004	.005–.007
			I	MD	KC7140						
		I	O	MD	KC7140	72	148	199	IPR	.003–.004	.005–.007
			I	MD	KC7140						
	3	S	O	MD	KCU40	104	289	351	IPR	.003–.004	.005–.007
			I	MD	KC7140						
		U	O	MD	KC7140	101	184	281	IPR	.003–.004	.005–.007
			I	MD	KC7140						
		I	O	MD	KC7140	72	131	199	IPR	.003–.004	.005–.007
			I	MD	KC7140						

Condition: S = Stable cutting conditions;
 U = Unstable cutting conditions;
 I = Interrupted cutting conditions

Pocket seat: I = Inboard insert;
 O = Outboard insert



■ HTS DFR™ • Inch

Indexable Drills

		Inch									
Material Group	Condition	Pocket Seat	Geometry	Grade	Cutting Speed – vc			Recommended Feed Rate (fz) by Diameter			
					Range – SFM			Ø	DFR03... .688–.750"	DFR04... .813–1.00"	
					min	Starting Value	max				
K	1	S	O	GD	KCPK10	260	561	750	IPR	.004–.008	.005–.011
			I	GD	KCPK10						
		U	O	LD	KCU25	211	384	510			
			I	LD	KCU25						
	I	O	LD	KCU40	131	236	316				
		I	LD	KCU40							
	2	S	O	GD	KCPK10	247	533	712	IPR	.004–.008	.005–.011
			I	GD	KCPK10						
		U	O	GD	KCU25	211	365	510			
			I	GD	KCU25						
		I	O	LD	KCU40	131	224	316			
			I	LD	KCU40						
3	S	O	GD	KCPK10	222	480	641	IPR	.004–.008	.005–.011	
		I	GD	KCPK10							
	U	O	GD	KCU25	195	328	473				
		I	GD	KCU25							
	I	O	GD	KCU40	113	202	274				
		I	GD	KCU40							
N	1	S	O	ST	KD1425	420	787	1176	IPR	.002–.004	.004–.007
			I	ST	KD1425						
		U	O	LD	KCU40	336	525	784			
			I	LD	KCU40						
	2	S	O	ST	KD1425	391	732	1094	IPR	.002–.004	.004–.007
			I	ST	KD1425						
		U	O	LD	KCU40	336	488	784			
			I	LD	KCU40						
	3	S	O	ST	KD1425	361	677	1011	IPR	.002–.004	.004–.007
			I	ST	KD1425						
		U	O	LD	KCU40	336	451	784			
			I	LD	KCU40						
	4	S	O	ST	KD1425	391	732	1094	IPR	.002–.004	.004–.007
			I	ST	KD1425						
		U	O	LD	KCU40	336	488	784			
			I	LD	KCU40						
	5	S	O	ST	KD1425	302	722	858	IPR	.002–.004	.004–.007
			I	ST	KD1425						
		U	O	LD	KCU40	235	459	549			
			I	LD	KCU40						
	I	O	LD	KCU40	151	295	351				
		I	LD	KCU40							

Condition: S = Stable cutting conditions;
 U = Unstable cutting conditions;
 I = Interrupted cutting conditions

Pocket seat: I = Inboard insert;
 O = Outboard insert

Difficult Applications Made Easy

Use DS and LP geometries to avoid bird nesting and long, stringy chips in low-carbon steel applications.

- The new DS insert style can be used on Drill Fix™ DFT™, HTS, and KSEM PLUS™ tooling systems.
- LP-style inserts can be used on Drill Fix DFSP™ as outboard inserts.
- Use the new geometries in all applications where long chips are an issue.

See pages J4–J59 for Drill Fix indexable drills.

See pages H102–H106, H108–H125, and H133 for KSEM PLUS A1 and B1 head systems.

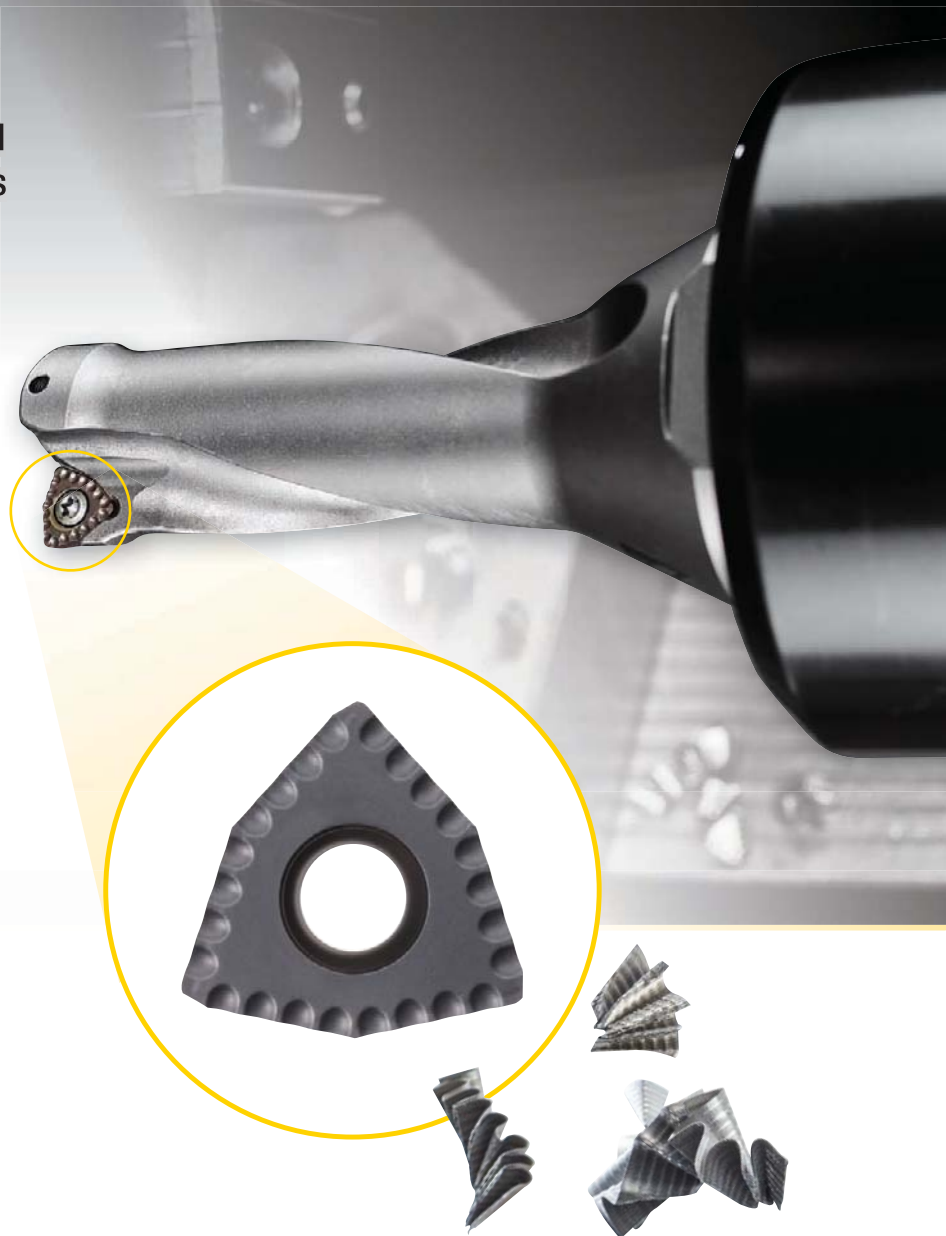

Experience the advantages at your Authorized Kennametal Distributor or at kennametal.com.



kennametal.com

- Head shipped with clamping and adjusting screws.
- Order pilot drill separately; see page J86.
- Order cartridges separately; see page J84.

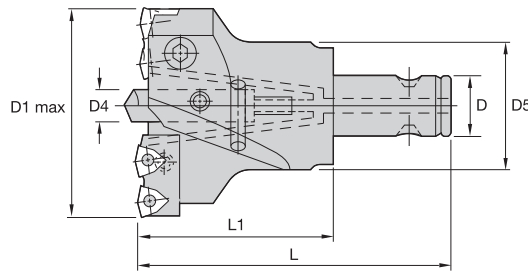

■ HTS Adjustable Heads with DFT™ Inserts

catalog number	D1		D1 max		D5	D	L	L1	pilot drill	cartridge interior	n	cartridge exterior	n	gage insert	ni	kg	lbs
	mm	in	mm	in													
3.76045R028V	45	1.770	50	1.970	28	13	85	50	B510S08.	3.77000R050V	1	3.77000R051V	1	DFT0303.	4	0.3	0.66
3.76050R028V	50	1.970	55	2.170	28	13	85	50	B510S08.	3.77000R052V	1	3.77000R053V	1	DFT0303.	4	0.4	0.88
3.76055R032V	55	2.170	58	2.280	33	16	100	60	B510S08.	3.77000R038V	1	3.77000R039V	1	DFT05T3.	4	0.4	0.88
3.76058R032V	58	2.280	63	2.480	33	16	100	60	B510S10.	3.77000R023V	1	3.77000R024V	1	DFT05T3.	4	0.4	0.88
3.76063R032V	63	2.480	68	2.680	33	16	100	60	B510S10.	3.77000R025V	1	3.77000R024V	1	DFT05T3.	4	0.4	0.88
3.76063R040V	63	2.480	68	2.680	41	22	115	70	B510S10.	3.77000R025V	1	3.77000R024V	1	DFT05T3.	4	0.5	1.10
3.76068R040V	68	2.680	73	2.870	41	22	115	70	B510S10.	3.77000R026V	1	3.77000R027V	1	DFT05T3.	4	0.8	1.76
3.76073R040V	73	2.870	78	3.070	41	22	115	70	B510S15.	3.77000R026V	1	3.77000R027V	1	DFT05T3.	4	0.8	1.76
3.76078R040V	78	3.070	84	3.310	41	22	115	70	B510S15.	3.77000R028V	1	3.77000R029V	1	DFT06T3.	4	0.8	1.76
3.76078R048V	78	3.070	84	3.310	49	27	120	70	B510S15.	3.77000R028V	1	3.77000R029V	1	DFT06T3.	4	0.9	1.98
3.76084R048V	84	3.310	90	3.540	49	27	120	70	B510S15.	3.77000R028V	1	3.77000R029V	1	DFT06T3.	4	1.0	2.20
3.76090R048V	90	3.540	96	3.780	49	27	120	70	B510S15.	3.77000R030V	1	3.77000R031V	1	DFT06T3.	4	1.0	2.20
3.76096R048V	96	3.780	102	4.020	49	27	120	70	B510S20.	3.77000R030V	1	3.77000R031V	1	DFT06T3.	4	1.1	2.43
3.76096R058V	96	3.780	102	4.020	59	32	130	80	B510S20.	3.77000R030V	1	3.77000R031V	1	DFT06T3.	4	1.2	2.65
3.76102R058V	102	4.020	108	4.250	59	32	130	80	B510S20.	3.77000R081V	1	3.77000R082V	1	DFT05T3.	6	1.7	3.75
3.76108R058V	108	4.250	115	4.530	59	32	130	80	B510S20.	3.77000R083V	1	3.77000R084V	1	DFT06T3.	6	1.8	3.97
3.76115R070V	115	4.530	122	4.800	71	40	145	90	B510S20.	3.77000R085V	1	3.77000R086V	1	DFT06T3.	6	2.9	6.39
3.76122R070V	122	4.800	130	5.120	71	40	145	90	B510S25.	3.77000R079V	1	3.77000R080V	1	DFT06T3.	6	2.9	6.39
3.76130R070V	130	5.120	140	5.510	71	40	145	90	B510S25.	3.77000R087V	1	3.77000R088V	1	DFT06T3.	6	3.0	6.61
3.76140R080V	140	5.510	150	5.910	81	50	160	100	B510S25.	3.77000R077V	1	3.77000R078V	1	DFT0704.	6	4.3	9.48
3.76150R080V	150	5.910	158	6.220	81	50	160	100	B510S25.	3.77000R075V	1	3.77000R076V	1	DFT0704.	6	4.5	9.92
3.76158R080V	158	6.220	162	6.380	81	50	160	100	B510S25.	3.77000R073V	1	3.77000R074V	1	DFT0704.	6	4.5	9.92
3.76162R080V	162	6.380	170	6.690	80	50	160	100	B510S30.	3.77000R048V	1	3.77000R049V	1	DFT0704.	6	4.5	9.92
3.76180R110	180	7.090	186	7.320	110	60	185	125	B510S30.	3.77000R030V	3	3.77000R031V	1	DFT06T3.	8	6.0	13.23
3.76195R110	195	7.680	201	7.910	110	60	185	125	B510S30.	3.77000R081V	3	3.77000R082V	1	DFT05T3.	12	6.5	14.33
3.76213R125	213	8.390	220	8.660	125	60	200	125	B510S30.	3.77000R083V	3	3.77000R084V	1	DFT06T3.	12	7.5	16.53
3.76230R160	230	9.060	240	9.450	160	80	230	150	B510S30.	3.77000R079V	2	3.77000R080V	2	DFT06T3.	12	8.5	18.74
3.76260R160 *	260	10.240	270	10.630	160	80	230	150	B510S30.	3.77000R077V	2	3.77000R078V	2	DFT06T3.	12	9.0	19.84

NOTE: *Made-to-order standard item. Standard pricing, manufacturing lead time, and minimum order quantity applies.
n: number of cartridges required by head.
ni: number of inserts required by head.

- Head shipped with clamping and adjusting screws.
- Order pilot drill separately; see page J86.
- Order cartridges separately; see pages J84–J85.

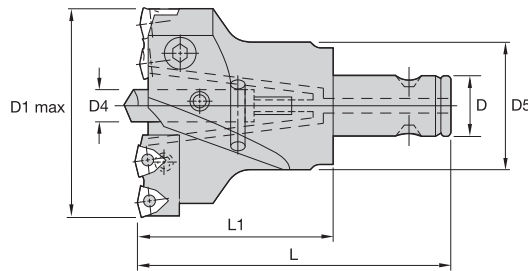

HTS Adjustable Heads • DFT™ and SPHX Inserts

catalog number	D1		D1 max		pilot drill	cartridge interior			gage insert	ni	cartridge exterior SPHX				
	mm	in	mm	in		n	cartridge interior 2	n			n	n	gage insert	ni	
3.76045R028V	45	1.770	50	1.970	B510S08.	3.77000R250V	1	—	—	DFT0303.	3	3.77000R251V	1	SPHX0703.	1
3.76050R028V	50	1.970	55	2.170	B510S08.	3.77000R252V	1	—	—	DFT0303.	3	3.77000R253V	1	SPHX0703.	1
3.76055R032V	55	2.170	58	2.280	B510S08.	3.77000R038V	1	—	—	DFT05T3.	3	3.77000R239V	1	SPHX0903.	1
3.76058R032V	58	2.280	63	2.480	B510S10.	3.77000R023V	1	—	—	DFT05T3.	3	3.77000R224V	1	SPHX0903.	1
3.76063R032V	63	2.480	68	2.680	B510S10.	3.77000R025V	1	—	—	DFT05T3.	3	3.77000R224V	1	SPHX0903.	1
3.76063R040V	63	2.480	68	2.680	B510S10.	3.77000R025V	1	—	—	DFT05T3.	3	3.77000R224V	1	SPHX0903.	1
3.76068R040V	68	2.680	73	2.870	B510S10.	3.77000R026V	1	—	—	DFT05T3.	3	3.77000R227V	1	SPHX0903.	1
3.76073R040V	73	2.870	78	3.070	B510S15.	3.77000R026V	1	—	—	DFT05T3.	3	3.77000R227V	1	SPHX0903.	1
3.76078R040V	78	3.070	84	3.310	B510S15.	3.77000R028V	1	—	—	DFT06T3.	3	3.77000R229V	1	SPHX0903.	1
3.76078R048V	78	3.070	84	3.310	B510S15.	3.77000R028V	1	—	—	DFT06T3.	3	3.77000R229V	1	SPHX0903.	1
3.76084R048V	84	3.310	90	3.540	B510S15.	3.77000R228V	1	—	—	DFT06T3.	3	3.77000R229V	1	SPHX0903.	1
3.76090R048V	90	3.540	96	3.780	B510S15.	3.77000R230V	1	—	—	DFT06T3.	3	3.77000R231V	1	SPHX0903.	1
3.76096R048V	96	3.780	102	4.020	B510S20.	3.77000R230V	1	—	—	DFT06T3.	3	3.77000R231V	1	SPHX0903.	1
3.76096R058V	96	3.780	102	4.020	B510S20.	3.77000R230V	1	—	—	DFT06T3.	3	3.77000R231V	1	SPHX0903.	1
3.76102R058V	102	4.020	108	4.250	B510S20.	3.77000R081V	1	—	—	DFT05T3.	5	3.77000R282V	1	SPHX0903.	1
3.76108R058V	108	4.250	115	4.530	B510S20.	3.77000R083V	1	—	—	DFT06T3.	5	3.77000R284V	1	SPHX1204.	1
3.76115R070V	115	4.530	122	4.800	B510S20.	3.77000R085V	1	—	—	DFT06T3.	5	3.77000R286V	1	SPHX1204.	1
3.76122R070V	122	4.800	130	5.120	B510S25.	3.77000R079V	1	—	—	DFT06T3.	5	3.77000R280V	1	SPHX1204.	1
3.76130R070V	130	5.120	140	5.510	B510S25.	3.77000R087V	1	—	—	DFT06T3.	5	3.77000R288V	1	SPHX1204.	1
3.76140R080V	140	5.510	150	5.910	B510S25.	3.77000R077V	1	—	—	DFT0704.	5	3.77000R278V	1	SPHX1505.	1
3.76150R080V	150	5.910	158	6.220	B510S25.	3.77000R075V	1	—	—	DFT0704.	5	3.77000R276V	1	SPHX1204.	1
3.76158R080V	158	6.220	162	6.380	B510S25.	3.77000R073V	1	—	—	DFT0704.	5	3.77000R274V	1	SPHX1204.	1
3.76162R08'0V	162	6.380	170	6.690	B510S30.	3.77000R248V	1	—	—	DFT0704.	5	3.77000R249V	1	SPHX1505.	1
3.76180R110	180	7.090	186	7.320	B510S30.	3.77000R230V	3	—	—	DFT06T3.	7	3.77000R231V	1	SPHX0903.	1
3.76195R110	195	7.680	201	7.910	B510S30.	3.77000R081V	3	—	—	DFT05T3.	11	3.77000R282V	1	SPHX0903.	1
3.76213R125	213	8.390	220	8.660	B510S30.	3.77000R083V	3	—	—	DFT06T3.	11	3.77000R284V	1	SPHX1204.	1
3.76230R160	230	9.060	240	9.450	B510S30.	3.77000R079V	2	3.77000R080V	1	DFT06T3.	11	3.77000R280V	1	SPHX1204.	1
3.76260R160 *	260	10.240	270	10.630	B510S30.	—	2	—	1	DFT06T3.	11	3.77000R078V	1	SPHX1204.	1

NOTE: *Made-to-order standard item. Standard pricing, manufacturing lead time, and minimum order quantity applies.
n: number of cartridges required by head.
ni: number of inserts required by head.

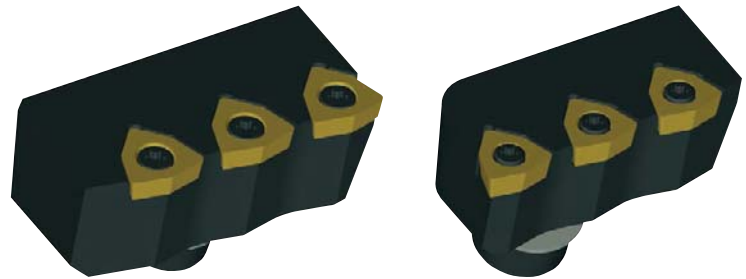

■ HTS Interior and Exterior Cartridges • DFT™ Inserts

Indexable Drills



catalog number	gage insert	number of inserts	insert screw	cartridge screw	fan washer	Nm	ft. lbs.
3.77000R023V	DFT05T3..	2	191.924	192.593	192.903	5,0	3.69
3.77000R024V	DFT05T3..	2	191.924	192.593	192.903	5,0	3.69
3.77000R025V	DFT05T3..	2	191.924	192.593	192.903	5,0	3.69
3.77000R026V	DFT05T3..	2	191.924	192.593	192.903	5,0	3.69
3.77000R027V	DFT05T3..	2	191.924	192.593	192.903	5,0	3.69
3.77000R028V	DFT06T3..	2	191.848	129.612	192.111	10,0	7.38
3.77000R029V	DFT06T3..	2	191.848	129.612	192.111	10,0	7.38
3.77000R030V	DFT06T3..	2	191.848	129.616	192.111	10,0	7.38
3.77000R031V	DFT06T3..	2	191.848	129.616	192.111	10,0	7.38
3.77000R038V	DFT05T3..	2	191.924	192.593	192.903	5,0	3.69
3.77000R039V	DFT05T3..	2	191.924	192.593	192.903	5,0	3.69
3.77000R048V	DFT0704..	3	191.698	125.830	192.112	35,0	25.81
3.77000R049V	DFT0704..	3	191.698	125.830	192.112	35,0	25.81
3.77000R050V	DFT0303..	2	192.432	192.592	192.902	5,0	3.69
3.77000R051V	DFT0303..	2	192.432	192.592	192.902	5,0	3.69
3.77000R052V	DFT0303..	2	192.432	192.592	192.902	5,0	3.69
3.77000R053V	DFT0303..	2	192.432	192.592	192.902	5,0	3.69
3.77000R073V	DFT0704..	3	191.698	—	192.112	35,0	25.81
3.77000R074V	DFT0704..	3	191.698	—	192.112	35,0	25.81
3.77000R075V	DFT0704..	3	191.698	—	192.112	35,0	25.81
3.77000R076V	DFT0704..	3	191.698	—	192.112	35,0	25.81
3.77000R077V	DFT0704..	3	191.698	—	192.112	35,0	25.81
3.77000R078V	DFT0704..	3	191.698	—	192.112	35,0	25.81
3.77000R079V	DFT06T3..	3	191.848	125.820	192.112	35,0	25.81
3.77000R080V	DFT06T3..	3	191.848	125.820	192.112	35,0	25.81
3.77000R081V	DFT05T3..	3	191.924	125.820	192.112	35,0	25.81
3.77000R082V	DFT05T3..	3	191.924	125.820	192.112	35,0	25.81
3.77000R083V	DFT06T3..	3	191.848	125.820	192.112	35,0	25.81
3.77000R084V	DFT06T3..	3	191.848	125.820	192.112	35,0	25.81
3.77000R085V	DFT06T3..	3	191.848	—	192.112	35,0	25.81
3.77000R086V	DFT06T3..	3	191.848	125.820	192.112	35,0	25.81
3.77000R087V	DFT06T3..	3	191.848	125.820	192.112	35,0	25.81
3.77000R088V	DFT06T3..	3	191.848	125.820	192.112	35,0	25.81

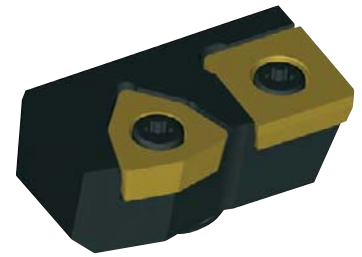

■ HTS Finishing Interior Cartridges • For Use with Exterior Cartridges Equipped with SPHX Inserts



catalog number	gage insert	number of inserts	insert screw	washer	Nm	ft. lbs.
3.77000R228V	DFT06T3..	2	191.848	192.111	10,0	7.38
3.77000R230V	DFT06T3..	2	191.848	192.111	10,0	7.38
3.77000R248V	DFT0704..	3	191.698	192.112	35,0	25.81
3.77000R250V	DFT0303..	2	192.432	192.902	5,0	3.69
3.77000R252V	DFT0303..	2	192.432	192.902	5,0	3.69

NOTE: Modified interior cartridges for use with SPHX-equipped exterior cartridges only.

■ HTS Finishing Exterior Cartridges • SPHX Inserts

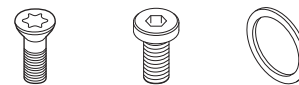

catalog number	gage insert inside	number of inserts	gage insert outside	number of inserts	insert screw	screw	washer	Nm	ft. lbs.
3.77000R224V	DFT05T3..	2	SPHX0903..	1	191.924	193.451	192.903	5,0	3.69
3.77000R227V	DFT05T3..	2	SPHX0903..	1	191.924	192.593	192.903	5,0	3.69
3.77000R229V	DFT06T3..	2	SPHX0903..	1	191.916	129.612	192.111	10,0	7.38
3.77000R231V	DFT06T3..	2	SPHX0903..	1	191.916	129.616	192.111	10,0	7.38
3.77000R239V	DFT05T3..	2	SPHX0903..	1	191.924	193.451	192.903	5,0	3.69
3.77000R249V	DFT0704..	3	SPHX1505..	1	191.698	125.830	192.112	35,0	25.81
3.77000R251V	DFT0303..	2	SPHX0703..	1	192.432	193.450	192.902	5,0	3.69
3.77000R253V	DFT0303..	2	SPHX0703..	1	192.432	193.450	192.902	5,0	3.69
3.77000R274V	DFT0704..	3	SPHX1505..	1	191.698	—	192.112	35,0	25.81
3.77000R276V	DFT0704..	3	SPHX1505..	1	191.698	—	192.112	35,0	25.81
3.77000R278V	DFT0704..	3	SPHX1505..	1	191.698	—	192.112	35,0	25.81
3.77000R280V	DFT06T3..	3	SPHX1204..	1	191.916	125.820	192.112	35,0	25.81
3.77000R282V	DFT05T3..	3	SPHX0903..	1	191.924	125.820	192.112	35,0	25.81
3.77000R284V	DFT06T3..	3	SPHX1204..	1	191.916	125.820	192.112	35,0	25.81
3.77000R286V	DFT06T3..	3	SPHX1204..	1	191.916	—	192.112	35,0	25.81
3.77000R288V	DFT06T3..	3	SPHX1204..	1	191.916	125.820	192.112	35,0	25.81

- Change drill diameter by shortening the outer cartridge.
- Shorten at 90° to the contact face A and the support face B.
- Shortening reduces the effective drill diameter by two times the amount removed.

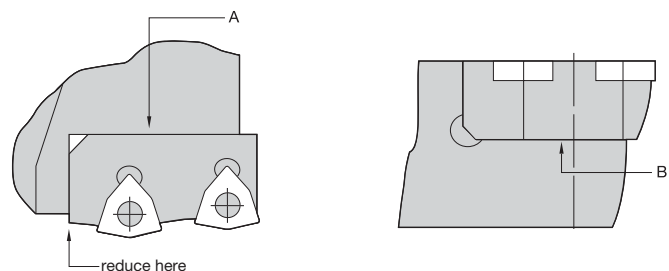

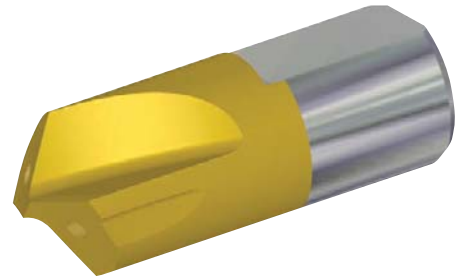
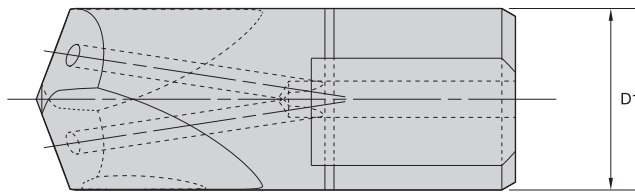

8–10mm sizes are without coolant.



■ HTS DFT™ • Pilot Drills

Indexable Drills

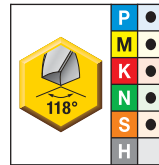
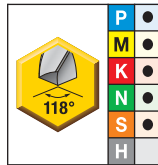
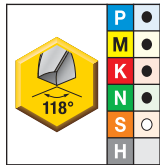

- first choice
- alternate choice

high-speed steel uncoated A30		high-speed steel coated AS3		carbide drills KC7315		D1	
						mm	in
B510S08000 A30	B510S08000 AS3	B511S08000 KC7315	8,00	0.315			
B510S10000 A30	B510S10000 AS3	B511S10000 KC7315	10,00	0.394			
B510S15000 A30	B510S15000 AS3	B511S15000 KC7315	15,00	0.591			
B510S20000 A30	B510S20000 AS3	B511S20000 KC7315	20,00	0.787			
B510S25000 A30	B510S25000 AS3	B511S25000 KC7315	25,00	0.984			
B510S30000 A30	B510S30000 AS3	B511S30000 KC7315	30,00	1.181			

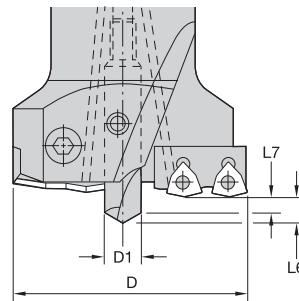

■ Pilot Drill Setting Lengths

D1		2–4 x D				4–6 x D				>6 x D			
		L6		L7		L6		L7		L6		L7	
mm	in	mm	in	mm	in	mm	in	mm	in	mm	in	mm	in
8,00	.315	3,00	.118	0,80	.032	3,40	.134	1,20	.047	3,80	.150	1,60	.063
10,00	.394	4,00	.158	1,30	.051	4,30	.169	1,60	.063	4,60	.181	1,90	.075
15,00	.591	6,20	.244	2,10	.083	6,50	.256	2,40	.095	6,80	.268	2,70	.106
20,00	.787	8,10	.319	2,60	.102	8,40	.331	2,90	.114	8,70	.343	3,20	.126
25,00	.984	10,50	.413	3,50	.138	7,40	.429	3,90	.154	11,30	.445	4,30	.169
30,00	1.181	12,30	.484	4,10	.158	12,80	.504	4,50	.177	13,20	.520	5,00	.197

- Reducers are shipped with drive ring and clamping screws.

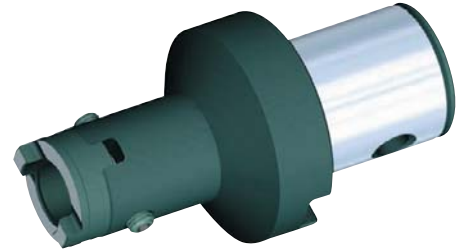
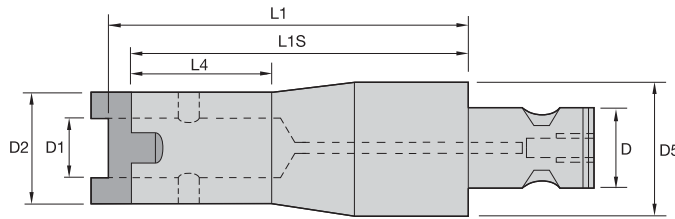

Reducers

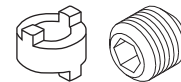

catalog number	D1 coupling size	D coupling size	D2		D5		L1		L1S		L4		drive ring	clamping screw	Nm	ft. lbs.
			mm	in	mm	in	mm	in	mm	in	mm	in				
5.34280R028080	13B	50	27,6	1.09	80,0	3.15	90,0	3.54	80,0	3.15	50,0	1.97	192.419	192.156	10,2	7.5
5.34280R032080	16	50	31,6	1.24	80,0	3.15	90,0	3.54	80,0	3.15	55,0	2.17	192.420	192.156	10,2	7.5
5.34280R040080	22	50	39,6	1.56	80,0	3.15	92,0	3.62	80,0	3.15	57,0	2.24	192.421	192.157	16,3	12.0
5.34280R048080	27	50	47,6	1.87	80,0	3.15	92,0	3.62	80,0	3.15	57,0	2.24	192.422	191.727	20,3	15.0
5.34280R058080	32	50	57,6	2.27	80,0	3.15	93,9	3.70	80,0	3.15	58,9	2.32	192.423	191.727	20,3	15.0
5.34240R032100	16	22	31,6	1.24	40,0	1.57	110,0	4.33	100,0	3.94	55,0	2.17	192.420	192.156	10,2	7.5
5.34248R040100	22	27	39,6	1.56	48,0	1.89	112,0	4.41	100,0	3.94	57,0	2.24	192.421	192.157	16,3	12.0
5.34258R048100	27	32	47,6	1.87	58,0	2.28	112,0	4.41	100,0	3.94	57,0	2.24	192.422	191.727	20,3	15.0
5.34270R058100	32	40	57,6	2.27	70,0	2.76	113,9	4.48	100,0	3.94	58,9	2.32	192.423	191.727	20,3	15.0
5.34280R070150	40	50	69,6	2.74	80,0	3.15	163,9	6.45	150,0	5.91	68,9	2.71	192.424	191.728	33,9	25.0

NOTE: Assemble components using recommended torque values.

- Extensions are shipped with drive ring and clamping screws.

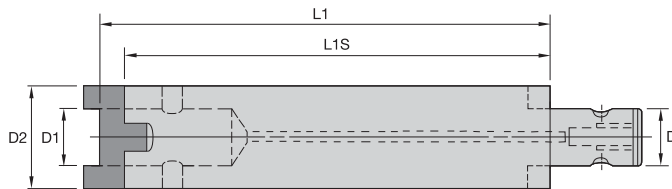

Extensions

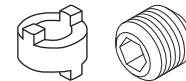

catalog number	D1 coupling size	D coupling size	D2		L1		L1S		drive ring	clamping screw	Nm	ft. lbs.
			mm	in	mm	in	mm	in				
5.34132R032100	16	16	32,0	1.26	110,0	4.33	100,0	3.94	192.420	192.156	10,2	7.5
5.34125R025150	13A	13A	25,0	0.98	160,0	6.30	150,0	5.91	193.371	193.372	10,2	7.5
5.34128R028150	13B	13B	28,0	1.10	160,0	6.30	150,0	5.91	192.419	192.156	10,2	7.5
5.34170R070186	40	40	70,0	2.76	200,0	7.87	186,0	7.32	192.424	191.728	33,9	25.0
5.34132R032200	16	16	32,0	1.26	210,0	8.27	200,0	7.87	192.420	192.156	10,2	7.5
5.34140R040200	22	22	40,0	1.57	212,0	8.35	200,0	7.87	192.421	192.157	16,3	12.0
5.34148R048200	27	27	48,0	1.89	212,0	8.35	200,0	7.87	192.422	191.727	20,3	15.0
5.34180R080204	50	50	80,0	3.15	220,0	8.66	204,0	8.03	192.425	191.728	33,9	25.0
5.34158R058300	32	32	58,0	2.28	314,0	12.36	300,0	11.81	192.423	191.727	33,9	25.0
5.34170R070300	40	40	70,0	2.76	314,0	12.36	300,0	11.81	192.424	191.728	33,9	25.0
5.34180R080300	50	50	80,0	3.15	316,0	12.44	300,0	11.81	192.425	191.728	33,9	25.0
5.34170R070500	40	40	70,0	2.76	514,0	20.24	500,0	19.69	192.424	191.728	33,9	25.0
5.34180R080500	50	50	80,0	3.15	516,0	20.32	500,0	19.69	192.425	191.728	33,9	25.0

NOTE: Assemble components using recommended torque values.

- Shanks are shipped with drive ring and clamping screws.

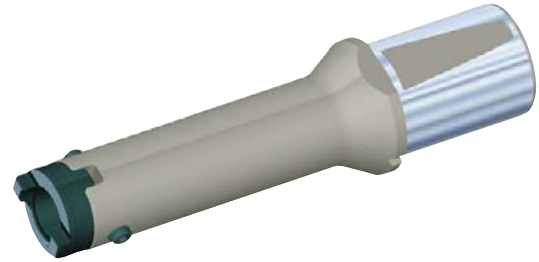
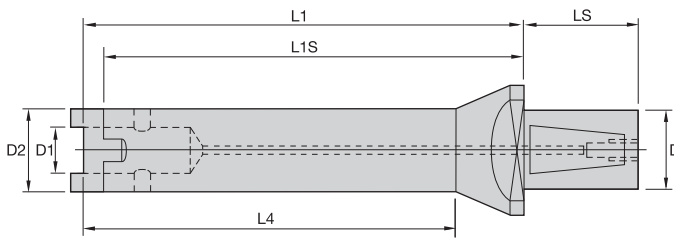

■ **Basic Shank WN/WD • Metric**

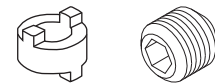

Indexable Drills

catalog number	D1 coupling size	D	D2	L1	L1S	L4	LS	drive ring	clamping screw	Nm
5.34032-025115	13A	32,0	25,0	125,0	115,0	110,0	58,0	193.371	193.372	10,2
5.34032-028115	13B	32,0	28,0	125,0	115,0	110,0	58,0	192.419	192.156	10,2
5.34032-032125	16	32,0	32,0	135,0	125,0	120,0	58,0	192.420	192.156	10,2
5.34050-040148	22	50,0	40,0	160,0	148,0	140,0	68,0	192.421	192.157	16,3
5.34050-048168	27	50,0	48,0	175,0	168,0	160,0	68,0	192.422	191.727	20,3
5.34050-058186	32	50,0	58,0	200,0	186,0	180,0	68,0	192.423	191.727	20,3
5.34032-025200	13A	32,0	25,0	210,0	200,0	195,0	58,0	193.371	193.372	10,2
5.34032-028200	13B	32,0	28,0	210,0	200,0	195,0	58,0	192.419	192.156	10,2
5.34050-032200	16	50,0	32,0	210,0	200,0	165,0	68,0	192.420	192.156	10,2
5.34050-025300	13A	50,0	25,0	310,0	300,0	270,0	68,0	193.371	193.372	10,2
5.34050-028300	13B	50,0	28,0	310,0	300,0	265,0	68,0	192.419	192.156	10,2
5.34050-040300	22	50,0	40,0	312,0	300,0	267,0	68,0	192.421	192.157	10,2
5.34050-048300	27	50,0	48,0	312,0	300,0	267,0	68,0	192.422	191.727	16,3
5.34050-058300	32	50,0	58,0	314,0	300,0	254,0	68,0	192.423	191.727	20,3
5.34050-032350	16	50,0	32,0	360,0	350,0	315,0	68,0	192.420	192.156	10,2
5.34050-025450	13A	50,0	25,0	460,0	450,0	420,0	68,0	193.371	193.372	10,2
5.34050-028450	13B	50,0	28,0	460,0	450,0	415,0	68,0	192.419	192.156	10,2
5.34050-040450	22	50,0	40,0	462,0	450,0	417,0	68,0	192.421	192.157	10,2
5.34050-048450	27	50,0	48,0	462,0	450,0	417,0	68,0	192.422	191.727	16,3
5.34050-058450	32	50,0	58,0	464,0	450,0	404,0	68,0	192.423	191.727	20,3
5.34050-032500	16	50,0	32,0	510,0	500,0	465,0	68,0	192.420	192.156	10,2
5.34050-040600	22	50,0	40,0	612,0	600,0	567,0	68,0	192.422	192.157	10,2
5.34050-048600	27	50,0	48,0	612,0	600,0	567,0	68,0	192.422	191.727	16,3
5.34050-058600	32	50,0	58,0	614,0	600,0	554,0	68,0	192.423	191.727	20,3

NOTE: Assemble components using recommended torque values.

- Shanks are shipped with drive ring and clamping screws.

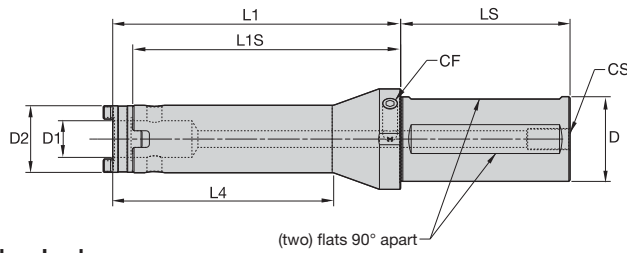

■ Flanged Shank • Inch

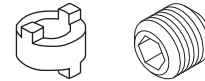

catalog number	D1 coupling size	D	D2	L1	L1S	L4	LS	drive ring	clamping screw	ft. lbs.
SSF150HTS130239 *	13A	1.50	0.98	2.39	2.00	0.39	3.75	193.371	193.372	7.5
SSF150HTS130450	13A	1.50	0.98	4.50	4.11	2.50	3.75	193.371	193.372	7.5
SSF150HTS130664	13A	1.50	0.98	6.64	6.25	4.65	3.75	193.371	193.372	7.5
SSF150HTS131114	13A	1.50	0.98	11.14	10.75	9.14	3.75	193.371	193.372	7.5
SSF150HTS131764	13A	1.50	0.98	17.64	17.25	15.64	3.75	193.371	193.372	7.5
SSF200HTS130239	13B	2.00	1.10	2.39	2.00	0.39	4.00	192.419	192.156	7.5
SSF200HTS130450 *	13B	2.00	1.10	4.50	4.11	2.50	4.00	192.419	192.156	7.5
SSF200HTS130664	13B	2.00	1.10	6.64	6.25	4.65	4.00	192.419	192.156	7.5
SSF200HTS131114	13B	2.00	1.10	11.14	10.75	9.14	4.00	192.419	192.156	7.5
SSF200HTS131764	13B	2.00	1.10	17.64	17.25	15.64	4.00	192.419	192.156	7.5
SSF200HTS160239	16	2.00	1.26	2.39	2.00	0.39	4.00	192.420	192.156	7.5
SSF200HTS160450 *	16	2.00	1.26	4.50	4.11	2.50	4.00	192.420	192.156	7.5
SSF200HTS160714	16	2.00	1.26	7.14	6.75	5.14	4.00	192.420	192.156	7.5
SSF200HTS161214	16	2.00	1.26	12.14	11.75	10.14	4.00	192.420	192.156	7.5
SSF200HTS161964	16	2.00	1.26	19.64	19.25	17.64	4.00	192.420	192.156	7.5
SSF200HTS220297	22	2.00	1.57	2.97	2.50	0.47	4.00	192.421	192.157	12.0
SSF200HTS220550	22	2.00	1.58	5.50	5.03	3.50	4.00	192.421	192.157	12.0
SSF200HTS220922	22	2.00	1.57	9.22	8.75	7.22	4.00	192.421	192.157	12.0
SSF200HTS221572	22	2.00	1.57	15.72	15.25	13.72	4.00	192.421	192.157	12.0
SSF200HTS222572	22	2.00	1.57	25.72	25.25	23.72	4.00	192.421	192.157	12.0
SSF200HTS270297	27	2.00	1.89	2.97	2.50	1.47	4.00	192.422	191.727	15.0
SSF200HTS270550	27	2.00	1.89	5.50	5.03	3.50	4.00	192.422	191.727	15.0
SSF200HTS271122	27	2.00	1.89	11.22	10.75	9.22	4.00	192.422	191.727	15.0
SSF200HTS271922	27	2.00	1.89	19.22	18.75	17.22	4.00	192.422	191.727	15.0
SSF200HTS273122	27	2.00	1.89	31.22	30.75	29.22	4.00	192.422	191.727	15.0
SSF200HTS320305 *	32	2.00	2.28	3.05	2.50	1.55	4.00	192.423	191.727	15.0
SSF200HTS320550	32	2.00	2.28	5.50	4.95	3.50	4.00	192.423	191.727	15.0
SSF200HTS320805	32	2.00	2.28	8.05	7.50	6.05	4.00	192.423	191.727	15.0
SSF200HTS321305	32	2.00	2.28	13.05	12.50	11.05	4.00	192.423	191.727	15.0
SSF200HTS321805	32	2.00	2.28	18.05	17.50	16.05	4.00	192.423	191.727	15.0
SSF250HTS400355	40	2.50	2.76	3.55	3.00	1.63	4.25	192.424	191.728	26.0
SSF250HTS400650 *	40	2.50	2.76	6.50	5.95	4.50	4.25	192.424	191.728	26.0
SSF250HTS401055	40	2.50	2.76	10.55	10.00	8.21	4.25	192.424	191.728	26.0
SSF250HTS401555	40	2.50	2.76	15.55	15.00	13.21	4.25	192.424	191.728	26.0
SSF250HTS402555	40	2.50	2.76	25.55	25.00	23.21	4.25	192.424	191.728	26.0
SSF300HTS500413 *	50	3.00	3.15	4.13	3.50	1.87	4.50	192.425	191.728	26.0
SSF300HTS500700 *	50	3.00	3.15	7.00	6.37	5.00	4.50	192.425	191.728	26.0
SSF300HTS501313	50	3.00	3.15	13.13	12.50	10.55	4.50	192.425	191.728	26.0
SSF300HTS502113	50	3.00	3.15	21.13	20.50	18.55	4.50	192.425	191.728	26.0
SSF300HTS503113	50	3.00	3.15	31.13	30.50	28.55	4.50	192.425	191.728	26.0

NOTE: Assemble components using recommended torque values.

*Made-to-order standard item. Standard pricing, manufacturing lead time, and minimum order quantity applies.



D	CF	CS	side pipe plug
1.500	1/8-27 NPT	1/4-18 NPT	HSFS0125
2.000	1/8-27 NPT	1/4-18 NPT	HSFS0125
2.500	1/8-27 NPT	1/4-18 NPT	HSFS0125
3.000	1/8-27 NPT	1/4-18 NPT	HSFS0125

- Shanks are shipped with drive ring and clamping screws.

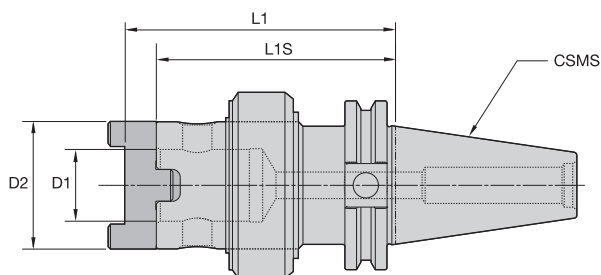

CV Taper Shank • Form AD • Rotary Coolant Ring

Indexable Drills

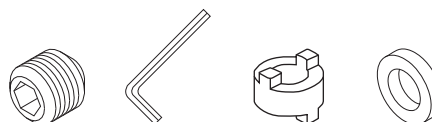

catalog number	CSMS system size	D1 coupling size	D2	L1	L1S	clamping screw	hex wrench	drive ring	coolant ring	ft. lbs.
CV50RMHTS13M394	CV50	13B	1.09	4.33	3.94	192.156	170.004	192.419	302.011	7.5
CV50RMHTS16M394	CV50	16	1.25	4.33	3.94	192.156	170.004	192.420	302.011	7.5
CV50RMHTS22M394	CV50	22	1.54	4.41	3.94	192.157	170.004	192.421	302.011	12.0
CV50RMHTS27M394	CV50	27	1.88	4.41	3.94	191.727	170.006	192.422	302.011	15.0
CV50RMHTS32M394 *	CV50	32	2.27	4.49	3.94	191.727	170.006	192.423	302.011	15.0
CV50RMHTS40M413	CV50	40	2.74	4.69	4.13	191.728	170.008	192.424	302.009	26.0
CV50RMHTS50M413	CV50	50	3.13	4.76	4.13	191.728	170.008	192.425	302.010	26.0

NOTE: Assemble components using recommended torque values.

*Made-to-order standard item. Standard pricing, manufacturing lead time, and minimum order quantity applies.

- Shanks are shipped with drive ring and clamping screws.

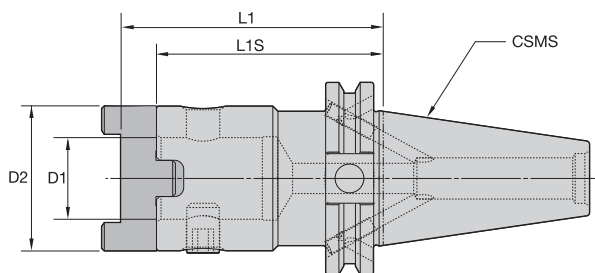

CV Taper Shank • Form B/AD Coolant

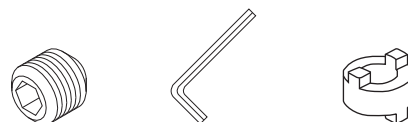

catalog number	CSMS system size	D1 coupling size	D2	L1	L1S	clamping screw	hex wrench	drive ring	ft. lbs.
CV50BHTS13M295	CV50	13B	1.10	3.35	2.95	192.156	170.004	192.419	7.5
CV50BHTS16M295	CV50	16	1.26	3.35	2.95	192.156	170.004	192.420	7.5
CV50BHTS22M295	CV50	22	1.57	3.43	2.95	192.157	170.004	192.421	12.0
CV50BHTS27M295	CV50	27	1.89	3.43	2.95	191.727	170.006	192.422	15.0
CV50BHTS32M314	CV50	32	2.28	3.70	3.15	191.727	170.006	192.423	15.0
CV50BHTS40M314	CV50	40	2.76	3.70	3.15	191.728	170.008	192.424	26.0
CV50BHTS50M314	CV50	50	3.15	3.78	3.15	191.728	170.008	192.425	26.0

NOTE: Assemble components using recommended torque values.

- Shanks are shipped with drive ring and clamping screw.

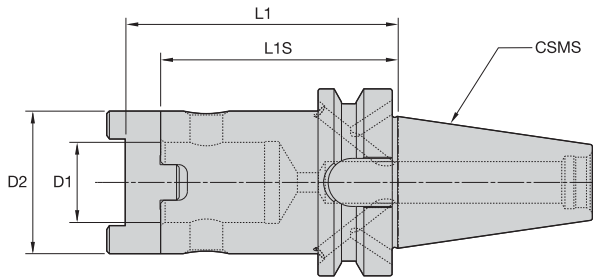

BT Taper Shank • Form B/AD Coolant

catalog number	CSMS system size	D1 coupling size	D2	L1		L1S		clamping screw	hex wrench	drive ring	Nm	ft. lbs.
				mm	in	mm	in					
BT50BHTS22075M	BT50	22	40,0	87,0	3.43	75,0	2.95	192.157	170.005	192.421	16,0	12.0
BT50BHTS32080M	BT50	32	58,0	94,0	3.70	80,0	3.15	MS1276	170.006	192.423	20,0	15.0
BT50BHTS40080M	BT50	40	70,0	94,0	3.70	80,0	3.15	191.728	170.008	192.424	34,0	26.0
BT50BHTS50080M	BT50	50	80,0	96,0	3.78	80,0	3.15	191.728	170.008	192.425	34,0	26.0

NOTE: Assemble components using recommended torque values.

- Shanks are shipped with drive ring and clamping screw.

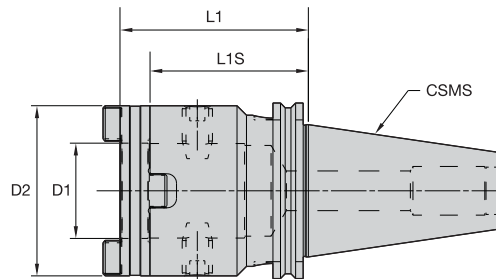

DV Taper Shank • Form B/AD Coolant

catalog number	CSMS system size	D1 coupling size	D2	L1		L1S		clamping screw	hex wrench	drive ring
				mm	in	mm	in			
5.36050-154040	DV50	40	70,0	100,0	3.94	84,0	3.31	191.728	170.008	192.424
5.36050-154050	DV50	50	90,0	100,0	3.94	84,0	3.31	191.729	170.008	192.426

NOTE: Assemble components using recommended torque values.

			40	(2x) MS2221S	2,5mm
			50	(2x) MS1296S	3mm

- Shanks are shipped with drive ring and clamping screw.

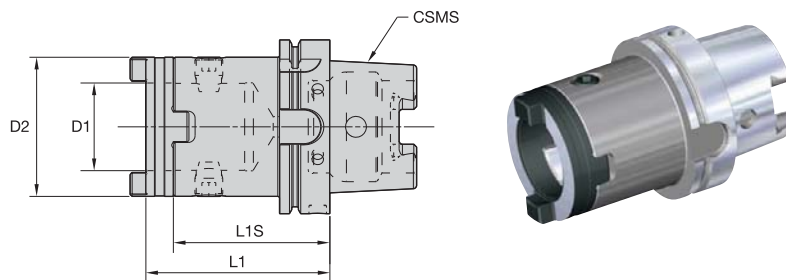

■ HSK100A Taper Shank

Indexable Drills

catalog number	CSMS system size	D1 coupling size	D2		L1		L1S		clamping screw	hex wrench	drive ring	Nm	ft. lbs.
			mm	in	mm	in	mm	in					
HSK100AHTS40085M	HSK100A	40	70,0	2.8	99,0	3.9	85,0	3.3	191.728	170.008	192.424	35,0	25.0
HSK100AHTS50090M	HSK100A	50	80,0	3.1	106,0	4.2	90,0	3.5	191.728	170.008	192.425	35,0	25.0

NOTE: Assemble components using recommended torque values.

- Shanks are shipped with drive ring and clamping screws.

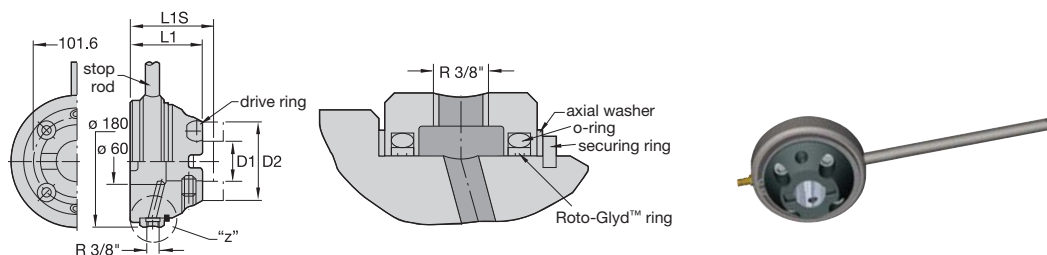

■ Flanged Adapter (Including Drive Ring)

catalog number	D1	D2		L1		L1S		kg	lbs
		mm	in	mm	in	mm	in		
5.34350-090100	50,00	90,0	3.54	116,0	4.57	100,0	3.94	10,0	21.94

NOTE: Adapter includes all items shown except the nipple. Nipple must be ordered separately.
If replacement becomes necessary, the nipple is manufactured with a predetermined breaking point for safety purposes.
Maximum RPM is 1500. Maximum pressure is 72 psi or 5 bar.

■ Spare Parts

catalog number	drive ring	clamping screw	coolant ring	O-ring	securing ring	axial washer	ROTO-GLYD ring	stop bar	nipple
5.34350-090100	192.426	191.729	302.014	192.731	192.126	192.158	192.730	460.716	192.759

HTS DFT™ • Metric

		Metric										
Material Group	Condition	Pocket Seat	Geometry	Grade	Cutting Speed – vc			Recommended Feed Rate (f) by Diameter				
					Range – m/min			Ø	DFT03... 45,00–55,00mm	DFT05... 55,00–78,00mm	DFT06... 78,00–140,00mm	DFT07... 140,00–270,00mm
					min	Starting Value	max					
P	1	S	O MD	KCU25	94	190	229	mm/r	0,06–0,10	0,08–0,12	0,10–0,14	0,13–0,19
			I MD	KCU40								
		U	O MD	KCU40	71	130	171	mm/r	0,06–0,10	0,08–0,12	0,10–0,14	0,13–0,19
			I MD	KC7140								
		I	O MD	KCU40	44	80	106	mm/r	0,06–0,10	0,08–0,12	0,10–0,14	0,13–0,19
			I MD	KC7140								
	2	S	O HP	KCU25	94	180	229	mm/r	0,10–0,14	0,12–0,18	0,12–0,18	0,12–0,20
			I HP	KCU40								
		U	O HP	KCU40	71	120	1714	mm/r	0,10–0,14	0,12–0,18	0,12–0,18	0,12–0,20
			I HP	KC7140								
		I	O HP	KCU40	44	70	106	mm/r	0,10–0,14	0,12–0,18	0,12–0,18	0,12–0,20
			I HP	KC7140								
	3	S	O HP	KCU25	70	140	169	mm/r	0,10–0,14	0,12–0,18	0,12–0,18	0,12–0,20
			I HP	KCU40								
		U	O HP	KCU40	50	100	121	mm/r	0,10–0,14	0,12–0,18	0,12–0,18	0,12–0,20
			I HP	KC7140								
		I	O HP	KCU40	30	60	72	mm/r	0,10–0,14	0,12–0,18	0,12–0,18	0,12–0,20
			I HP	KC7140								
	4	S	O HP	KCU25	94	120	229	mm/r	0,10–0,14	0,12–0,18	0,12–0,18	0,12–0,20
			I HP	KCU40								
		U	O HP	KCU40	71	100	171	mm/r	0,10–0,14	0,12–0,18	0,12–0,18	0,12–0,20
			I HP	KC7140								
		I	O HP	KCU40	44	80	106	mm/r	0,10–0,14	0,12–0,18	0,12–0,18	0,12–0,20
			I HP	KC7140								
5	S	O HP	KCU25	78	100	190	mm/r	0,05–0,07	0,06–0,08	0,06–0,10	0,08–0,12	
		I HP	KCU40									
	U	O HP	KCU40	47	60	114	mm/r	0,05–0,07	0,06–0,08	0,06–0,10	0,08–0,12	
		I HP	KC7140									
	I	O HP	KCU40	31	40	76	mm/r	0,05–0,07	0,06–0,08	0,06–0,10	0,08–0,12	
		I HP	KC7140									
6	S	O HP	KCU25	74	95	180	mm/r	0,04–0,07	0,05–0,08	0,06–0,10	0,08–0,12	
		I HP	KCU40									
	U	O HP	KCU40	45	57	108	mm/r	0,04–0,07	0,05–0,08	0,06–0,10	0,08–0,12	
		I HP	KC7140									
	I	O HP	KCU40	30	38	72	mm/r	0,04–0,07	0,05–0,08	0,06–0,10	0,08–0,12	
		I HP	KC7140									
M	1	S	O MD	KCU25	48	110	134	mm/r	0,07–0,11	0,12–0,18	0,14–0,20	0,16–0,22
			I MD	KCU40								
		U	O MD	KCU40	31	70	86	mm/r	0,07–0,11	0,12–0,18	0,14–0,20	0,16–0,22
			I MD	KC7140								
		I	O MD	KC7140	22	50	61	mm/r	0,07–0,11	0,12–0,18	0,14–0,20	0,16–0,22
			I MD	KC7140								
	2	S	O MD	KCU25	48	99	134	mm/r	0,07–0,11	0,12–0,18	0,14–0,20	0,16–0,22
			I MD	KCU40								
		U	O MD	KCU40	31	63	86	mm/r	0,07–0,11	0,12–0,18	0,14–0,20	0,16–0,22
			I MD	KC7140								
		I	O MD	KC7140	22	45	61	mm/r	0,07–0,11	0,12–0,18	0,14–0,20	0,16–0,22
			I MD	KC7140								
3	S	O MD	KCU25	48	88	134	mm/r	0,07–0,11	0,12–0,18	0,14–0,20	0,16–0,22	
		I MD	KCU40									
	U	O MD	KCU40	31	56	86	mm/r	0,07–0,11	0,12–0,18	0,14–0,20	0,16–0,22	
		I MD	KC7140									
	I	O MD	KC7140	22	40	61	mm/r	0,07–0,11	0,12–0,18	0,14–0,20	0,16–0,22	
		I MD	KC7140									

Condition: S = Stable cutting conditions;
 U = Unstable cutting conditions;
 I = Interrupted cutting conditions

Pocket seat: I = Inboard insert;
 O = Outboard insert

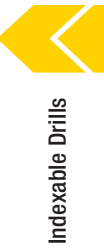

■ HTS DFT™ • Metric

Indexable Drills

					Metric									
Material Group	Condition	Pocket Seat	Geometry	Grade	Cutting Speed – vc			Recommended Feed Rate (f) by Diameter						
					Range – m/min			Ø	DFT03... 45,00–55,00mm	DFT05... 55,00–78,00mm	DFT06... 78,00–140,00mm	DFT07... 140,00–270,00mm		
					min	Starting Value	max							
K	1	S	O	HP	KCPK10	94	171	229	mm/r	0,11–0,20	0,13–0,27	0,15–0,31	0,17–0,33	
			I	HP	KCPK10									
		U	O	HP	KCU25	64	117	156	mm/r	0,11–0,20	0,13–0,27	0,15–0,31	0,17–0,33	
	2	S	O	HP	KCPK10	94	162	229	mm/r	0,11–0,20	0,13–0,27	0,15–0,31	0,17–0,33	
			I	HP	KCPK10									
		U	O	HP	KCU25	64	111	156	mm/r	0,11–0,20	0,13–0,27	0,15–0,31	0,17–0,33	
	3	S	O	HP	KCU40	40	72	96	mm/r	0,11–0,20	0,13–0,27	0,15–0,31	0,17–0,33	
			I	HP	KCU40									
		U	O	HP	KCU40	40	68	96	mm/r	0,11–0,20	0,13–0,27	0,15–0,31	0,17–0,33	
	N	1	S	O	ST	KD1425	154	240	358	mm/r	0,06–0,09	0,11–0,19	0,12–0,20	0,14–0,25
				I	ST	KD1425								
			U	O	HP	KC7140	102	160	239	mm/r	0,06–0,09	0,11–0,19	0,12–0,20	0,14–0,25
2		S	O	HP	KC7140	67	104	155	mm/r	0,06–0,09	0,11–0,19	0,12–0,20	0,14–0,25	
			I	HP	KC7140									
		U	O	HP	KCU40	102	149	239	mm/r	0,06–0,09	0,11–0,19	0,12–0,20	0,14–0,25	
3		S	O	HP	KCU40	67	97	155	mm/r	0,06–0,09	0,11–0,19	0,12–0,20	0,14–0,25	
			I	HP	KCU40									
		U	O	ST	KD1425	154	206	358	mm/r	0,06–0,09	0,11–0,19	0,12–0,20	0,14–0,25	
4		S	O	HP	KCU40	102	138	239	mm/r	0,06–0,09	0,11–0,19	0,12–0,20	0,14–0,25	
			I	HP	KCU40									
		U	O	HP	KCU40	67	89	155	mm/r	0,06–0,09	0,11–0,19	0,12–0,20	0,14–0,25	
5	S	O	ST	KD1425	154	223	358	mm/r	0,06–0,09	0,11–0,19	0,12–0,20	0,14–0,25		
		I	ST	KD1425										
	U	O	LD	KC7140	102	149	239	mm/r	0,06–0,09	0,11–0,19	0,12–0,20	0,14–0,25		
S	1	S	O	HP	KC7140	24	40	49	mm/r	0,04–0,07	0,05–0,08	0,07–0,10	0,07–0,10	
			I	HP	KC7140									
		U	O	HP	KC7140	18	30	37	mm/r	0,04–0,07	0,05–0,08	0,07–0,10	0,07–0,10	
	2	S	O	HP	KC7140	15	25	30	mm/r	0,04–0,07	0,05–0,08	0,07–0,10	0,07–0,10	
			I	HP	KC7140									
		U	O	HP	KC7140	25	35	48	mm/r	0,04–0,07	0,05–0,08	0,07–0,10	0,07–0,10	
	2	S	O	HP	KC7140	18	25	34	mm/r	0,04–0,07	0,05–0,08	0,07–0,10	0,07–0,10	
			I	HP	KC7140									
		U	O	HP	KC7140	14	20	27	mm/r	0,04–0,07	0,05–0,08	0,07–0,10	0,07–0,10	

Condition: S = Stable cutting conditions;
 U = Unstable cutting conditions;
 I = Interrupted cutting conditions

Pocket seat: I = Inboard insert;
 O = Outboard insert

■ HTS DFT™ • Inch

Inch													
Material Group	Condition	Pocket Seat	Geometry	Grade	Cutting Speed – vc			Recommended Feed Rate (f) by Diameter					
					Range – SFM			Ø	DFT03... 1.77–2.17"	DFT05... 2.17–3.07"	DFT06... 3.07–5.51"	DFT07... 5.51–10.63"	
					min	Starting Value	max						
P	1	S	O	MD	KCU25	309	623	750	IPR	.002–.004	.003–.005	.004–.006	.005–.007
			I	MD	KCU40								
		U	O	MD	KCU40	231	427	561	IPR	.002–.004	.003–.005	.004–.006	.005–.007
	I		MD	KC7140									
	I	O	MD	KCU40	143	262	348	IPR	.002–.004	.003–.005	.004–.006	.005–.007	
			MD	KC7140									
		I	O	HP	KCU25	309	591	750	IPR	.004–.006	.005–.007	.005–.007	.005–.008
	I		HP	KCU40									
	2	U	O	HP	KCU40	231	394	561	IPR	.004–.006	.005–.007	.005–.007	.005–.008
			I	HP	KC7140								
		I	O	HP	KCU40	143	230	348	IPR	.004–.006	.005–.007	.005–.007	.005–.008
	I		HP	KC7140									
	3	S	O	HP	KCU25	229	459	555	IPR	.004–.006	.005–.007	.005–.007	.005–.008
			I	HP	KCU40								
		U	O	HP	KCU40	163	328	396	IPR	.004–.006	.005–.007	.005–.007	.005–.008
	I		HP	KC7140									
	I	O	HP	KCU40	98	197	238	IPR	.004–.006	.005–.007	.005–.007	.005–.008	
			I	HP	KC7140								
		I	O	HP	KCU25	309	394	750	IPR	.004–.006	.005–.007	.005–.007	.005–.008
	I		HP	KCU40									
	4	U	O	HP	KCU40	231	328	561	IPR	.004–.006	.005–.007	.005–.007	.005–.008
			I	HP	KC7140								
		I	O	HP	KCU40	143	262	348	IPR	.004–.006	.005–.007	.005–.007	.005–.008
	I		HP	KC7140									
5	S	O	HP	KCU25	257	328	622	IPR	.002–.003	.002–.003	.002–.004	.003–.005	
		I	HP	KCU40									
	U	O	HP	KCU40	154	197	373	IPR	.002–.003	.002–.003	.002–.004	.003–.005	
I		HP	KC7140										
I	O	HP	KCU40	103	131	250	IPR	.002–.003	.002–.003	.002–.004	.003–.005		
		I	HP	KC7140									
	I	O	HP	KCU25	244	312	591	IPR	.002–.003	.002–.003	.002–.004	.003–.005	
I		HP	KCU40										
6	U	O	HP	KCU40	146	187	355	IPR	.002–.003	.002–.003	.002–.004	.003–.005	
		I	HP	KC7140									
	I	O	HP	KCU40	98	125	238	IPR	.002–.003	.002–.003	.002–.004	.003–.005	
I		HP	KC7140										
M	1	S	O	MD	KCU25	159	361	439	IPR	.003–.004	.005–.007	.006–.008	.006–.009
			I	MD	KCU40								
		U	O	MD	KCU40	101	230	281	IPR	.003–.004	.005–.007	.006–.008	.006–.009
	I		MD	KC7140									
	I	O	MD	KC7140	72	164	199	IPR	.003–.004	.005–.007	.006–.008	.006–.009	
			MD	KC7140									
		I	O	MD	KCU25	159	325	439	IPR	.003–.004	.005–.007	.006–.008	.006–.009
	I		MD	KCU40									
	2	U	O	MD	KCU40	101	207	281	IPR	.003–.004	.005–.007	.006–.008	.006–.009
			I	MD	KC7140								
		I	O	MD	KC7140	72	148	199	IPR	.003–.004	.005–.007	.006–.008	.006–.009
	I		MD	KC7140									
3	S	O	MD	KCU25	159	289	439	IPR	.003–.004	.005–.007	.006–.008	.006–.009	
		I	MD	KCU40									
	U	O	MD	KCU40	101	184	281	IPR	.003–.004	.005–.007	.006–.008	.006–.009	
I		MD	KC7140										
I	O	MD	KC7140	72	131	199	IPR	.003–.004	.005–.007	.006–.008	.006–.009		
		I	MD	KC7140									

Condition: S = Stable cutting conditions;
 U = Unstable cutting conditions;
 I = Interrupted cutting conditions

Pocket seat: I = Inboard insert;
 O = Outboard insert

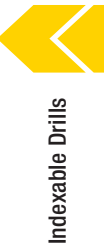

■ HTS DFT™ • Inch

		Inch											
Material Group	Condition	Pocket Seat	Geometry	Grade	Cutting Speed – vc			Recommended Feed Rate (f) by Diameter					
					Range – SFM			Ø	DFT03... 1.77–2.17"	DFT05... 2.17–3.07"	DFT06... 3.07–5.51"	DFT07... 5.51–10.63"	
					min	Starting Value	max						
K	1	S	O	HP	KCPK10	309	561	750	IPR	.004–.008	.005–.011	.006–.012	.007–.013
			I	HP	KCPK10								
		U	O	HP	KCU25	211	384	510	IPR	.004–.008	.005–.011	.006–.012	.007–.013
	2	S	O	HP	KCPK10	309	533	750	IPR	.004–.008	.005–.011	.006–.012	.007–.013
			I	HP	KCPK10								
		U	O	HP	KCU25	211	365	510	IPR	.004–.008	.005–.011	.006–.012	.007–.013
	3	S	O	HP	KCU40	131	236	316	IPR	.004–.008	.005–.011	.006–.012	.007–.013
			I	HP	KCU40								
		U	O	HP	KCU40	131	224	316	IPR	.004–.008	.005–.011	.006–.012	.007–.013
N	1	S	O	HP	KCPK10	294	480	712	IPR	.004–.008	.005–.011	.006–.012	.007–.013
			I	HP	KCPK10								
		U	O	HP	KCU25	195	328	473	IPR	.004–.008	.005–.011	.006–.012	.007–.013
S	1	S	O	HP	KCU25	113	202	274	IPR	.004–.008	.005–.011	.006–.012	.007–.013
			I	HP	KCU40								
		U	O	HP	KCU40	113	202	274	IPR	.004–.008	.005–.011	.006–.012	.007–.013
	2	S	O	ST	KD1425	504	787	1176	IPR	.002–.004	.004–.007	.005–.008	.006–.010
			I	ST	KD1425								
		U	O	HP	KC7140	336	525	784	IPR	.002–.004	.004–.007	.005–.008	.006–.010
	3	S	O	HP	KC7140	218	341	510	IPR	.002–.004	.004–.007	.005–.008	.006–.010
			I	HP	KC7140								
		U	O	HP	KCU40	336	488	784	IPR	.002–.004	.004–.007	.005–.008	.006–.010
4	S	O	HP	KCU40	218	317	510	IPR	.002–.004	.004–.007	.005–.008	.006–.010	
		I	HP	KCU40									
	U	O	ST	KD1425	504	677	1176	IPR	.002–.004	.004–.007	.005–.008	.006–.010	
5	S	O	HP	KCU40	336	451	784	IPR	.002–.004	.004–.007	.005–.008	.006–.010	
		I	HP	KCU40									
	U	O	HP	KCU40	218	293	510	IPR	.002–.004	.004–.007	.005–.008	.006–.010	
6	S	O	ST	KD1425	504	732	1176	IPR	.002–.004	.004–.007	.005–.008	.006–.010	
		I	ST	KD1425									
	U	O	LD	KC7140	336	488	784	IPR	.002–.004	.004–.007	.005–.008	.006–.010	
7	S	O	LD	KC7140	218	317	510	IPR	.002–.004	.004–.007	.005–.008	.006–.010	
		I	LD	KC7140									
	U	O	ST	KD1425	368	722	858	IPR	.002–.004	.004–.007	.005–.008	.006–.010	
8	S	O	HP	KC7140	235	459	549	IPR	.002–.004	.004–.007	.005–.008	.006–.010	
		I	HP	KC7140									
	U	O	HP	KC7140	151	295	351	IPR	.002–.004	.004–.007	.005–.008	.006–.010	
9	S	O	HP	KC7140	80	131	160	IPR	.002–.003	.002–.003	.003–.004	.003–.004	
		I	HP	KC7140									
	U	O	HP	KC7140	60	98	120	IPR	.002–.003	.002–.003	.003–.004	.003–.004	
10	S	O	HP	KC7140	50	82	100	IPR	.002–.003	.002–.003	.003–.004	.003–.004	
		I	HP	KC7140									
	U	O	HP	KC7140	82	115	158	IPR	.002–.003	.002–.003	.003–.004	.003–.004	
11	S	O	HP	KC7140	58	82	112	IPR	.002–.003	.002–.003	.003–.004	.003–.004	
		I	HP	KC7140									
	U	O	HP	KC7140	46	66	90	IPR	.002–.003	.002–.003	.003–.004	.003–.004	

Condition: S = Stable cutting conditions;
 U = Unstable cutting conditions;
 I = Interrupted cutting conditions

Pocket seat: I = Inboard insert;
 O = Outboard insert

